

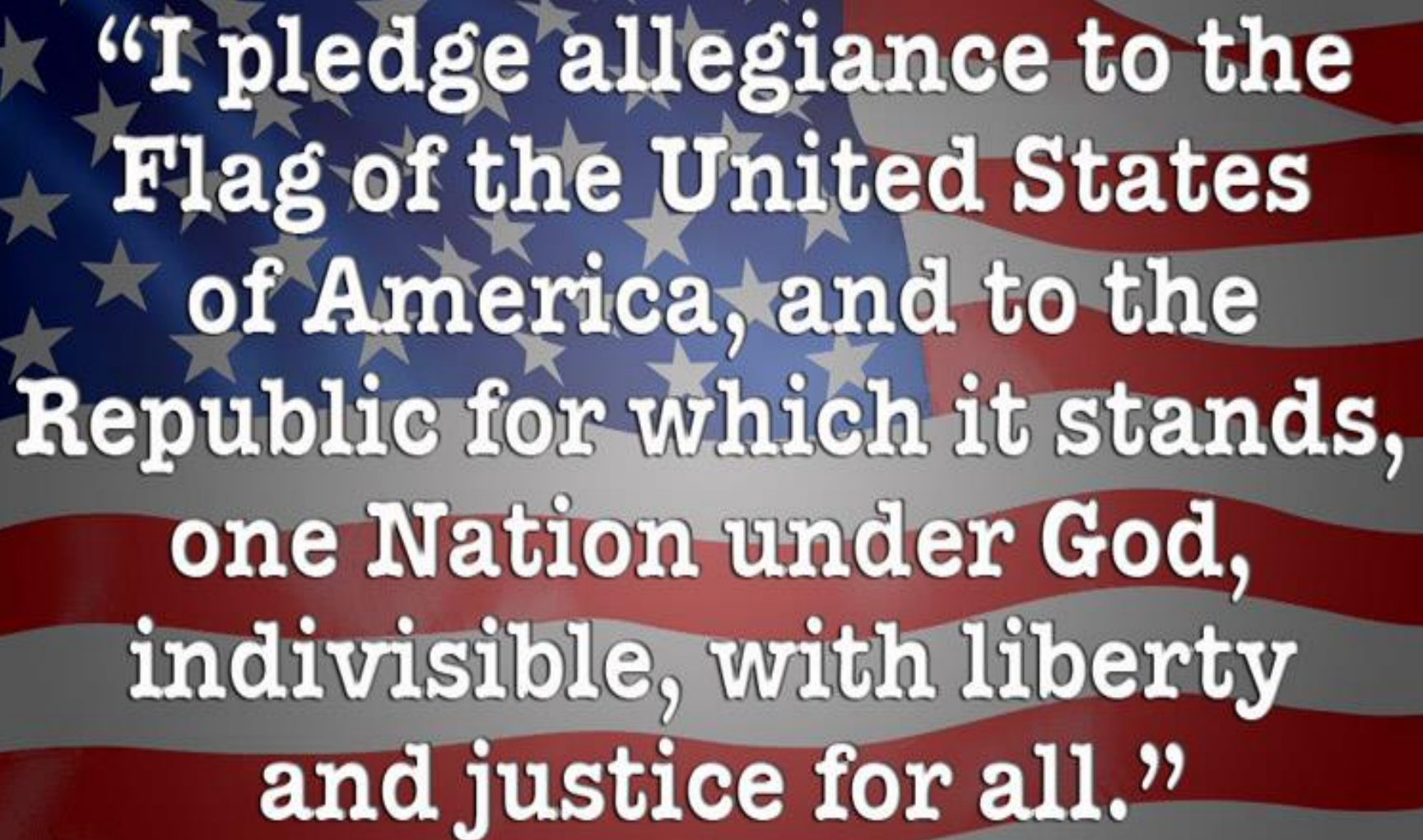

# LAKE COUNTY 2024 PRIMARY ELECTION TRAINING MATERIALS

---

**WELCOME POLL WORKERS**

The background of the slide is a stylized American flag with a blue field of white stars on the left and red and white stripes on the right. The text is overlaid on this background in a white, bold, serif font with a black outline.

**“I pledge allegiance to the  
Flag of the United States  
of America, and to the  
Republic for which it stands,  
one Nation under God,  
indivisible, with liberty  
and justice for all.”**

# Lake County Board of Elections & Registration

Michelle R. Fajman  
LeAnn J. Angerman  
Jerry Schmitt  
Genevieve Gasparovic  
Joel Rodriguez  
Ruthann Hoagland  
Andre Manzo  
James Oliver

Director  
Assistant Director  
Election Administrator  
Assistant Election Administrator  
Registration Administrator  
Assistant Registration Administrator  
Chief Mechanic  
Assistant Chief Mechanic

## Board Members

Kevin C. Smith  
Michael Brown  
Robert Tribble  
John P. Reed  
Michael Mellon





## \*\*INSPECTORS\*\*

PLEASE CALL ALL OF THE WORKERS  
AND INVITE THEM TO SET UP YOUR  
POLL LOCATION ON MONDAY.

*This isn't about needing help. This is about a bipartisan process.*

# ELECTION SUPPLIES

This Black Bag Contains ELECTION Supplies.

PLEASE VERIFY THE CONTENTS OF THIS BAG PRIOR TO  
ELECTION MORNING.

CONTACT ELECTION BOARD AT 219-755-3795 IF BAG IS MISSING OR  
HAS INCORRECT SUPPLIES.

VOTING MACHINE TECHNICIAN NUMBERS ARE LISTED IN  
THE BLACK BAG (BEFORE ELECTION DAY CALL (219-755-3845)

FOR ALL OTHER CONCERNS CONTACT 219-755-3795



**MUST Post Sample Ballots, Voter's Rights and Voting Instructions**

**Post Vote Here Signs, Stretch Rope from the Entrance to voting room, 50ft full length**

**Set up the Jet Pack/Mi-fi/Hotspot/Cradle-point, Printer and then Poll Pad (keep cell phones away)**

**Make sure to have at least 1-2 feet of space Between each unit**

**Turn on Poll Pad, Do a Test Print and Verify Zero Count**

**Make Sure there is a Clear Path to all Voting Machines**

# MEALS

- **Make sure you make arrangements for food during the day.**
    - **Bring a lunch**
    - **Have someone bring you lunch to the door**
    - **Order takeout or a pizza**
- (Try to meet the delivery person at the door, they can't come in without credentials.)

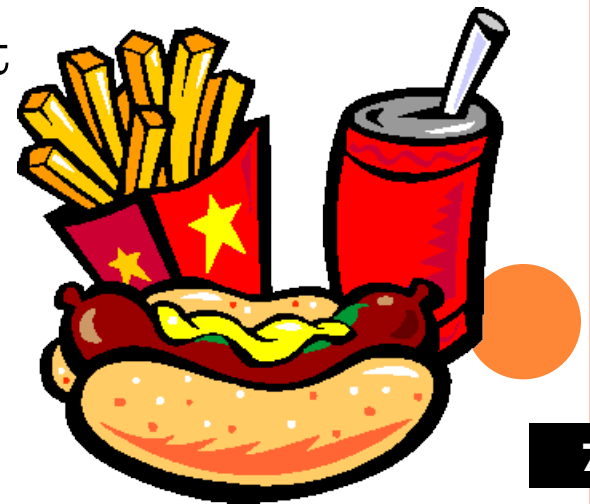

LAKE COUNTY, INDIANA  
PRESENTS

INFINITY  
MICROVOTE  
VOTING  
SYSTEM





# MICROVOTE SUPPLIES

## WHAT TO LOOK FOR

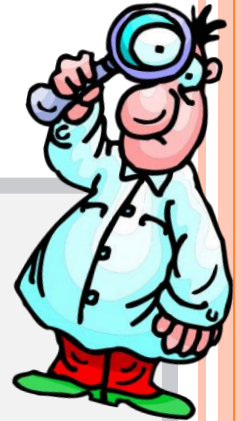

VOTING MACHINE(S)  
MICROVOTE – INFINITY

PRECINCT BAG

VOTING MACHINE PRINTER  
POLL PAD PRINTER

POWER CORD FOR ALL PRINTERS

VOTING MACHINE PRINTER CABLE (Silver, Already Attached)

Two Stylus and an Extra Roll of Paper for Each Printer

DOUBLE TALK BOX & HEADPHONES

\*PRECINCT ENVELOPE \_\_\_\_\_ (Large WHITE Envelope)

START CARDS (Green)

VOTE CARDS (Blue)

TALLY CARDS(Red) (inside of the Tally Envelope)

**Note! Combined/Split precincts will have an encoder with charging Cable (See Encoder Manual in the Precinct Bag).**

# ON MONDAY START VOTING MACHINE SYSTEM

CHECK LUGGAGE TAG

SET UP MACHINE



CHECK BALLOT

PRINT ZERO TAPE



SET CARRYING BOOTH UP-RIGHT

USE A TABLE IF AVAILABLE



Do Not Place the Booth Under Direct Light or in view of a camera to ensure voter privacy.

VVPAT (Voter Verifiable Paper Audit Trail) is a mechanism used in some electronic voting systems to provide a paper record so the voter can verify their selections in print prior to casting their ballot.

VVPAT will be used on some machines now with full implantation by July 1, 2024.



VVPAT needs to be located inside the privacy curtain on the right side.



TRY TO PLACE ALL CORDS AWAY FROM  
TRAFFIC AREAS

IF NECESSARY, TAPE DOWN ALL POWER  
CORDS THAT ARE IN TRAFFIC AREAS



# ON MONDAY NIGHT START MICROVOTE VOTING SYSTEM

- **TURN ON THE  
POWER**
- **THE SWITCH IS  
LOCATED ON  
THE BACK OF  
THE VOTING  
PANEL ON THE  
RIGHT HAND  
SIDE**

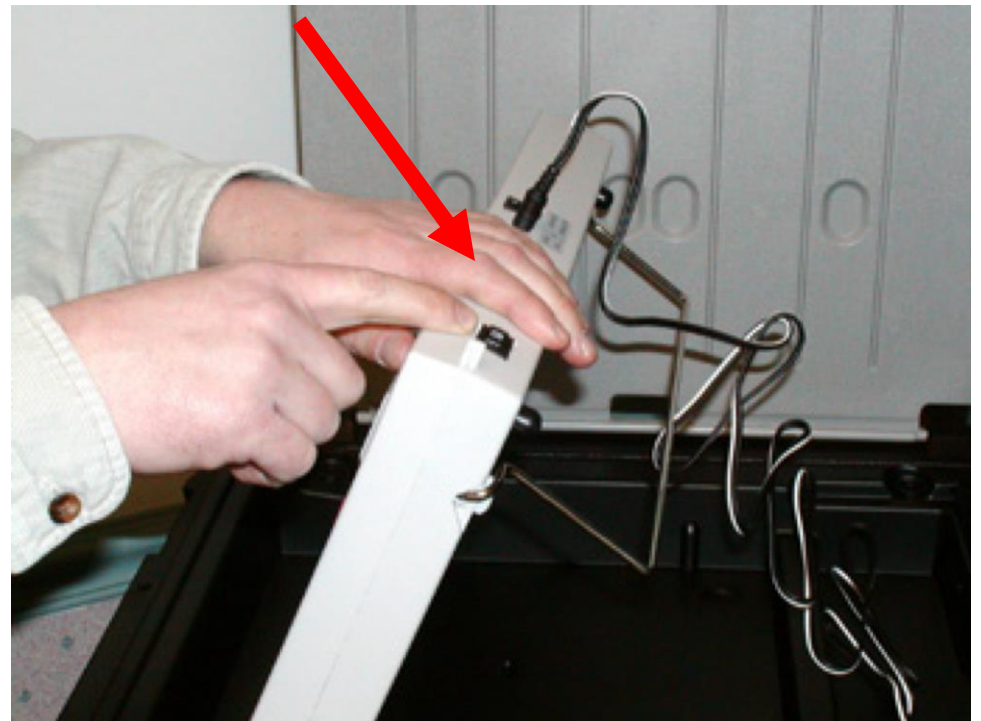

# GREEN START CARD

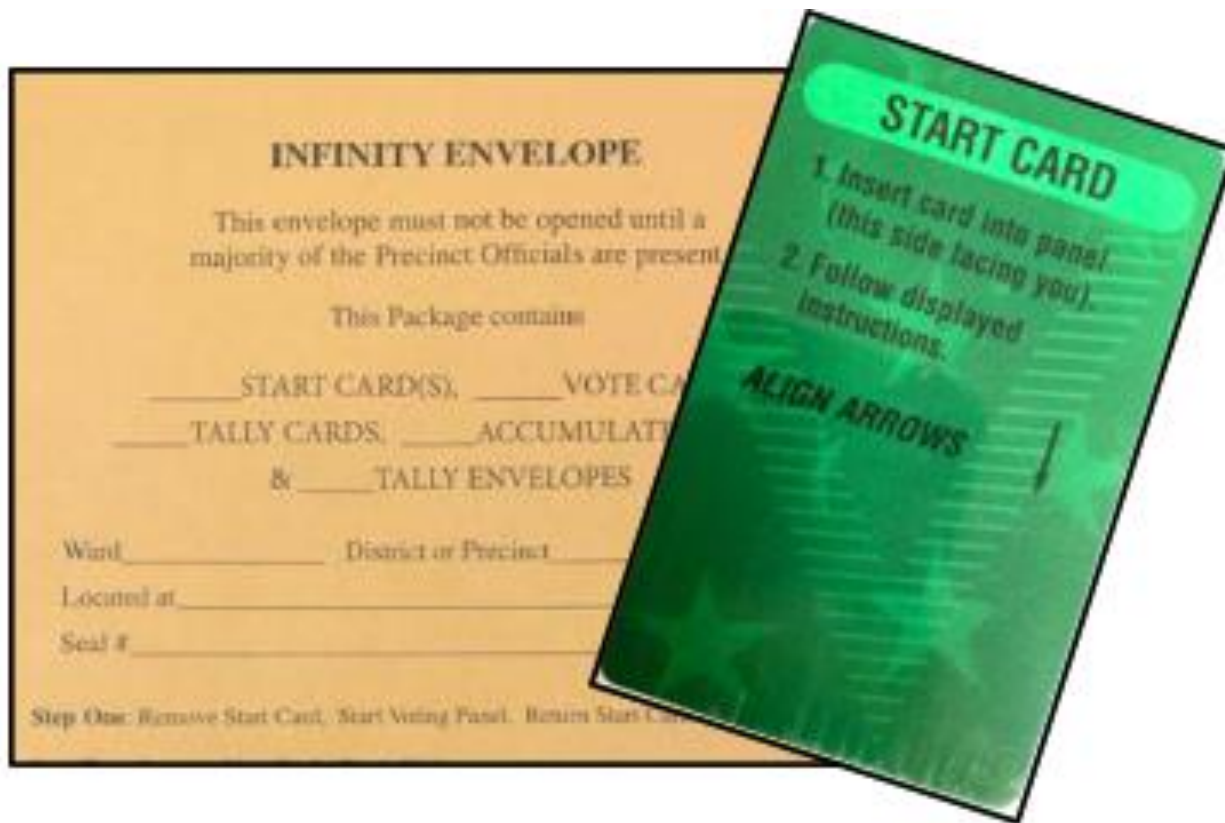

# \*WHEN THE SCREEN GOES BLANK\*

LINE UP THE ARROWS,  
INSERT THE  
GREEN START CARD  
IN THE SLOT UNTIL  
IT STOPS AND THE  
SCREEN COMES ON

THAT SIGNALS THE  
CARD IS INSERTED  
ALL THE WAY IN THE  
SLOT .





**FOLLOW THE DIRECTIONS DISPLAYED ON THE SCREEN**

**YOU WILL BE ASKED TO ENTER A PASSWORD LISTED ON INSPECTOR ENVELOPE TO ACTIVATE THE VOTING PANEL. USE THE GREY BUTTONS TO THE LEFT OF THE NUMBERS**

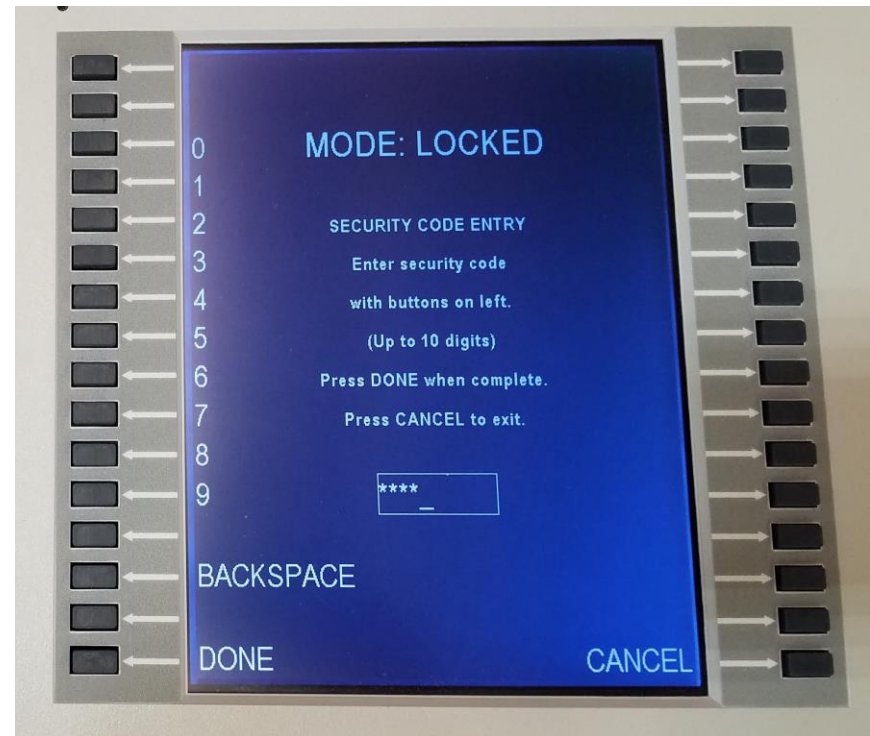

**ENTER THE SECURITY PASSWORD, THEN PRESS THE GRAY BUTTON TO THE LEFT OF THE WORD DONE**

Passwords are in the inspector envelope in the inspector kit

# CHECK BALLOT AND TEST PRINT

**YOU WILL SEE SEVERAL CHOICES – CHECK BUTTONS, CHECK DISPLAY, SHOW BALLOT, PRINT ZERO PROOF, , START ELECTION, LIGHTEN DISPLAY, AND DARKEN DISPLAY**

**PRESS THE SHOW BALLOT BUTTON AND COMPARE THEM TO THE SAMPLE BALLOTS IN THE BLACK ROLLER BAG**

**WHEN AT THE LAST PAGE OF EACH BALLOT, PRESS THE RED CAST VOTE BUTTON TO RETURN TO THE MENU**

**PRESS THE PRINT ZERO PROOF BUTTON TO TEST THAT THE PRINTER IS WORKING CORRECTLY**

**WHEN THESE STEPS ARE COMPLETED REMOVE THE GREEN CARD AND TURN OFF MACHINE**

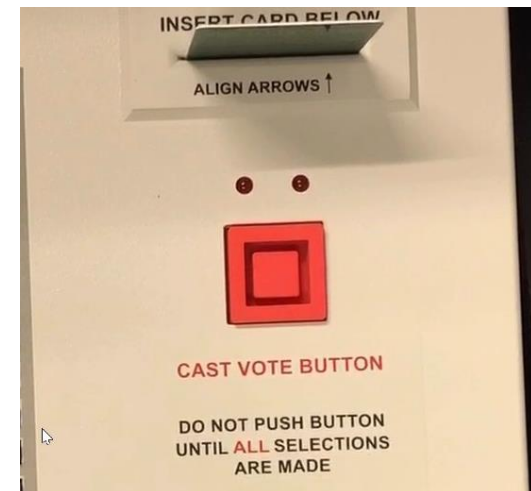
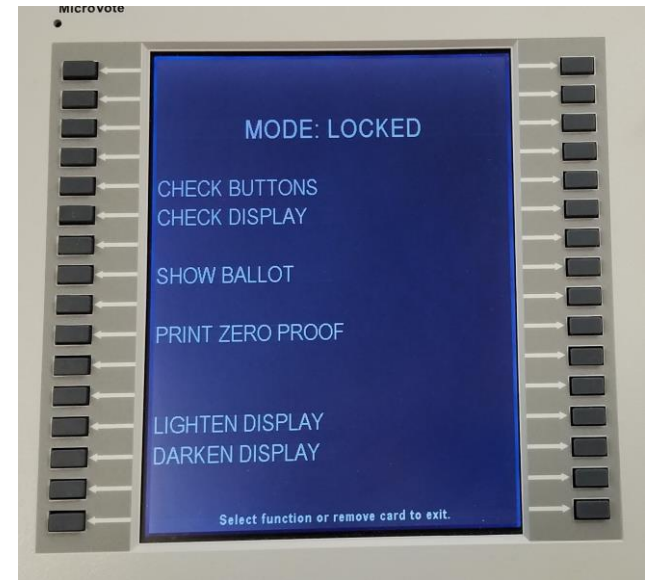

# TUESDAY ELECTION DAY OPENING THE POLLS

1. Arrive at polling location between 5:00 and 5:30 a.m. Don't replace any workers until at least 6:10 a.m.
2. Swear in all Poll Workers if you've not already done so.
3. Check Ballot if not done on Monday, print Zero Proof Tape and place in white envelope #1 and start Election
4. Set up Jet Pack/Hot Spot/Cradle Point, Poll Pad Printer and then Poll Pad
5. Complete steps 1-4 in the **Lavender** Inspector Book.
6. Put up 50 Foot rope with "Chute Starts Here" sign
7. If you received ADA equipment at your polling place, be sure to install.
8. Announce opening of polls at 6:00 AM
9. Write down how many voters were in line when you OPENED/12:30PM/CLOSED.  
(FORM # PRE-1(Inspector Oath Book, STEP 6 )



# ON TUESDAY START MICROVOTE VOTING SYSTEM

- **TURN ON THE POWER**
- **THE SWITCH IS LOCATED ON THE BACK OF THE VOTING PANEL ON THE RIGHT HAND SIDE**

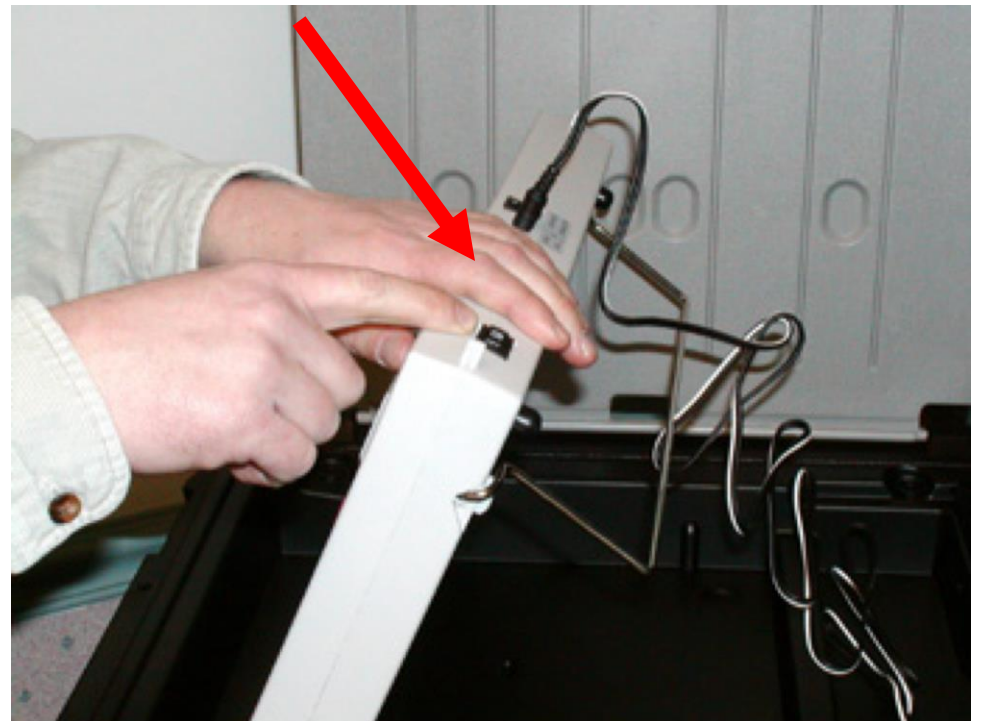

# **\*WHEN THE SCREEN GOES BLANK\***

**LINE UP THE ARROWS,  
INSERT THE  
GREEN START CARD  
IN THE SLOT UNTIL  
IT STOPS AND THE  
SCREEN COMES ON**

**THAT SIGNALS THE  
CARD IS INSERTED  
ALL THE WAY IN THE  
SLOT .**

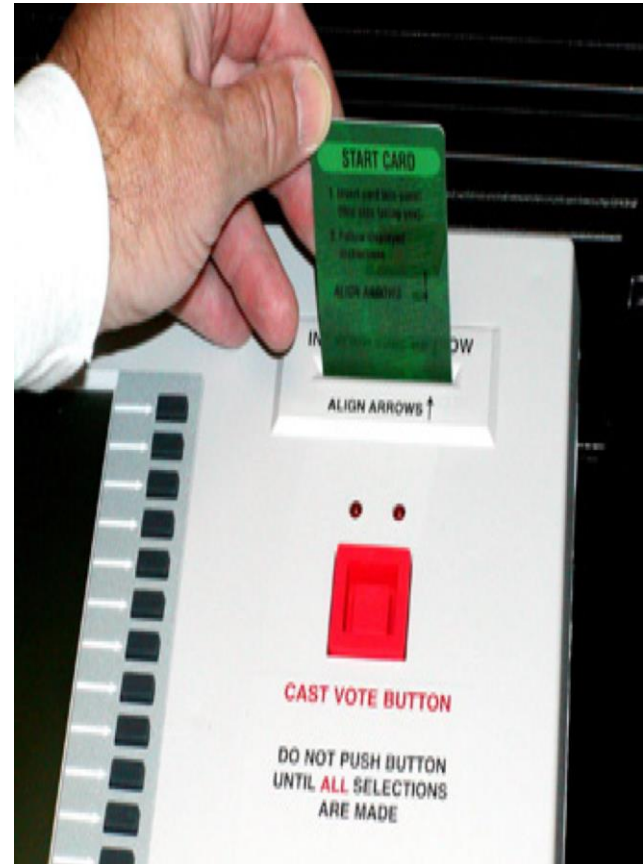

# PASSWORD

## FOLLOW DIRECTION DISPLAYED ON THE SCREEN

YOU WILL BE ASKED TO ENTER A PASSWORD LISTED ON INSPECTOR ENVELOPE TO ACTIVATE THE VOTING PANEL. USE THE GREY BUTTONS TO THE LEFT OF THE NUMBERS

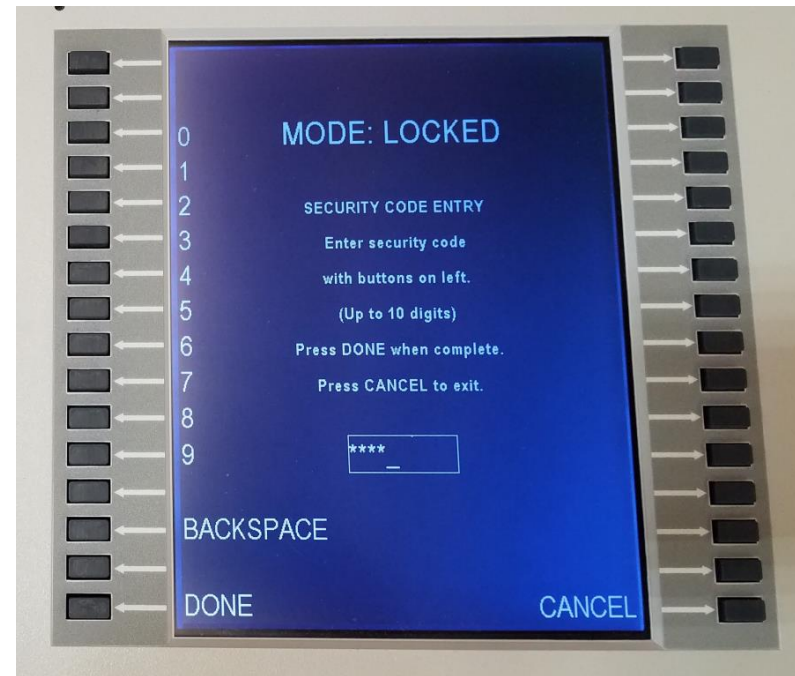

ENTER THE SECURITY PASSWORD, THEN PRESS THE GRAY BUTTON TO THE LEFT OF THE WORD DONE

Passwords are in the inspector envelope in the inspector kit

# NOW YOU ARE READY TO START THE ELECTION

- **YOU WILL SEE SEVERAL CHOICES - BUTTON CHECK, DISPLAY CHECK, ZERO PROOF, LIGHTEN DISPLAY, DARKEN DISPLAY AND START ELECTION**
- **YOU MUST PRINT A ZERO PROOF, LEAVE GREEN START CARD IN, THEN PRESS THE START ELECTION BUTTON. MACHINE WILL NOT START ELECTION UNLESS YOU PRINT A ZERO PROOF TAPE FIRST. YOU WILL BE INSTRUCTED TO PRESS THE BUTTON NEXT TO START**

**WHEN INSTRUCTED BY THE PANEL, REMOVE THE GREEN CARD AND YOU ARE READY FOR VOTING**

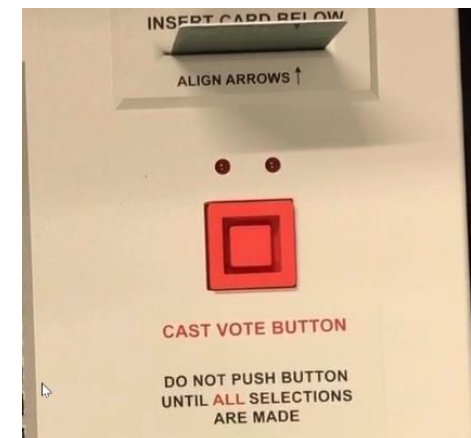
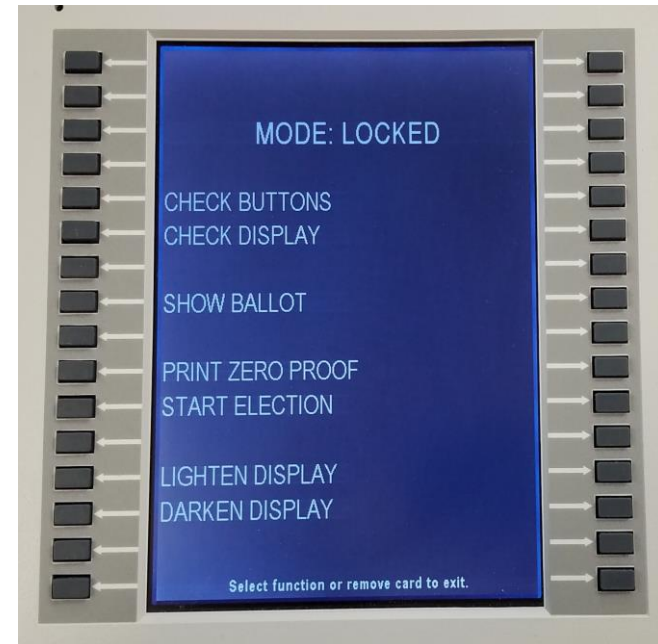

- REPEAT THIS PROCESS ON ALL THE VOTING PANELS AT YOUR PRECINCT
- THE SCREEN WILL SHOW
- “MODE: VOTING ENABLED”
- RETURN THE GREEN START CARD TO WHITE ENVELOPE #1



# ALL JUDGES WILL NEED A BLUE VOTE CARD

## ATTACHED TO A WRIST COIL

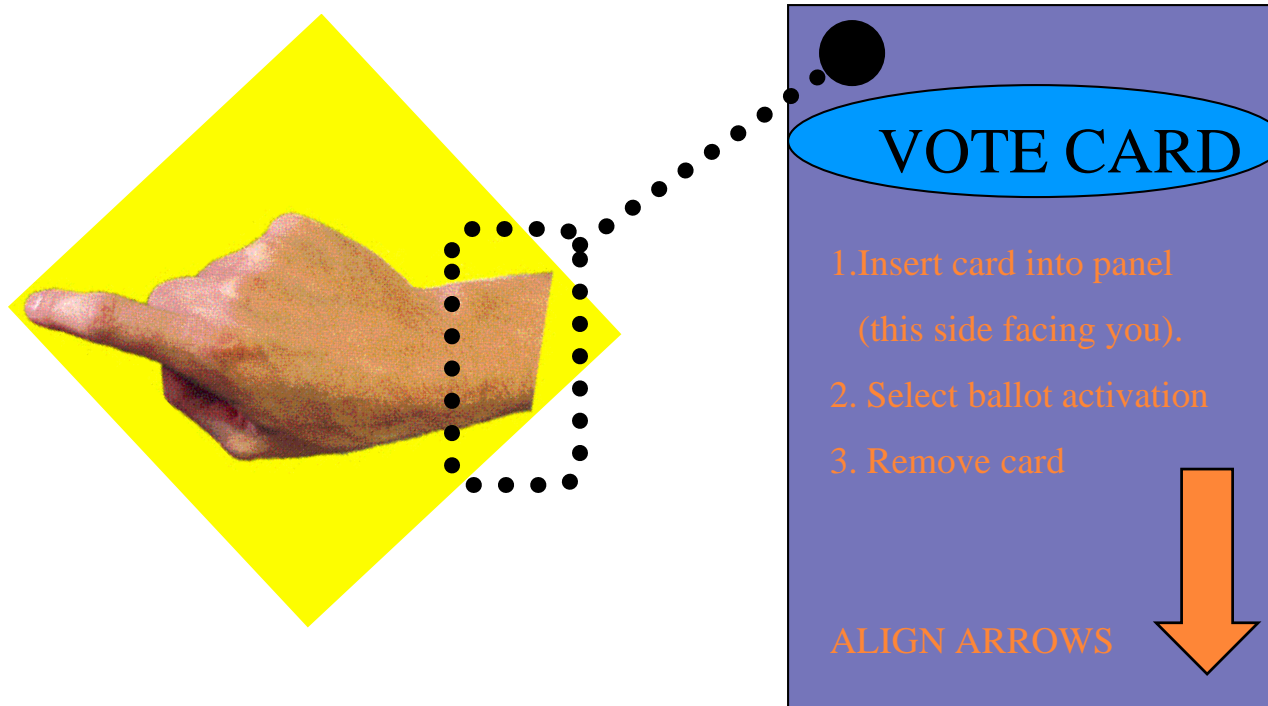

KEEP COIL ON WRIST AT ALL TIMES,

**NEVER ALLOW VOTER TO HANDLE THE VOTE CARD**

# MACHINE OPERATION BALLOT ACTIVATION

- ALIGN ARROWS
- INSERT THE BLUE VOTE CARD INTO THE VOTING PANEL, SELECT THE PARTY THE VOTER DECLARES
- WHEN THE BALLOT APPEARS ON THE SCREEN, **REMOVE THE VOTE CARD**
- ALLOW THE VOTER TO ENTER THE BOOTH



# CAST VOTE

- ❖ A VOTER MUST MAKE ONE SELECTION AND VIEW ALL PAGES
- ❖ AFTER ALL SELECTIONS HAVE BEEN MADE, PRESS THE BUTTON TO CONFIRM VOTE. THE TWO LIGHTS ABOVE THE RED CAST VOTE BUTTON WILL COME ON.
- ❖ THE VOTER WILL PUSH THE CAST VOTE BUTTON TO RECORD THEIR VOTE.
- ❖ AFTER THE VOTER PUSHES THE CAST VOTE BUTTON. THE VOTER WILL HEAR A BEEP.
- ❖ (THANK YOU ) WILL BE DISPLAYED ON THE SCREEN. INDICATING THE VOTE HAS BEEN RECORDED.

# INTRODUCING THE POLL PAD, HOTSPOT/JETPACK, AND PRINTER



Lake County  
Board of Elections

Lake County, IN

Michelle R. Fajman, Director

Do not un-seal Poll Pad envelope until  
Tuesday Morning. Both Parties must be present.

# TURNING ON THE HOTSPOT/JETPACK

## Hotspot/Mifi

1. Connect the Hotspot/Mifi to a power source and hold the Power button (typically on the top edge of the device) for approximately 5-8 seconds until you see the device activate.
2. Reposition the location of the Hotspot/Mifi to maximize your connectivity level. Check the number of bars on the home screen to determine signal strength.



# TURNING ON THE HOTSPOT/JET PACK

## Cradlepoint

1. Screw the 2 or more rabbit ears into the Cradlepoint and connect it to a power source



**IF YOU ARE HAVING CONNECTIVITY ISSUES WITH YOUR POLL PADS,**  
**CONTACT THE COUNTY OFFICE FOR GUIDANCE**

# PRINTER SETUP

## Election Day Printer Setup

**Step 1** - Position the Printer and Poll Pad on the table.

**Step 2** - Connect the Printer power cord.

- (1) Connect the AC adapter to the power cord.
- (2) Connect the AC adapter to the connector on the printer.
- (3) Insert the power cable plug into an AC outlet.

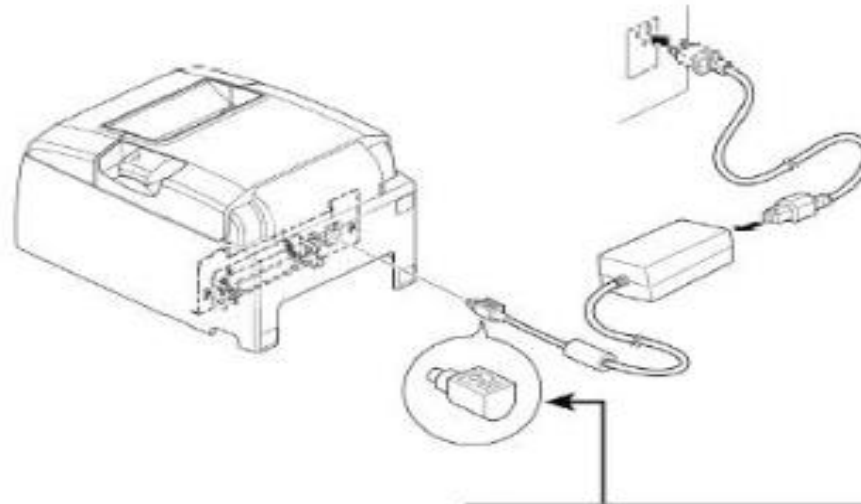

**⚠ CAUTION**

*When disconnecting the cable, take hold of the cable connector to pull it out. Releasing the lock makes it easy to disconnect the connector.*

*Pulling the cable excessively could cause damage to the connector.*

# PRINTER SETUP

**Step 3 - Turn Printer ON (switch on left side of printer).**  
The power lamp on the front control panel will light Green and the Printer and Poll Pad will connect to each other automatically.

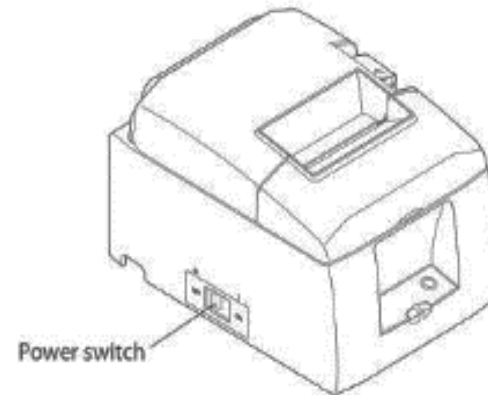



# CHANGING PAPER ON THE PRINTER

## Changing Paper in the Poll Pad Printer

The Printer will be distributed with a full roll paper at the start of the day and will process approximately 1,000 voters. The printer is designed for “drop in” paper loading. To change the paper:

**Step 1** - Push the cover access lever on the top of the printer backwards in the direction of the arrow and lift the printer top upwards.

Remove and discard the remaining paper & plastic spindle.

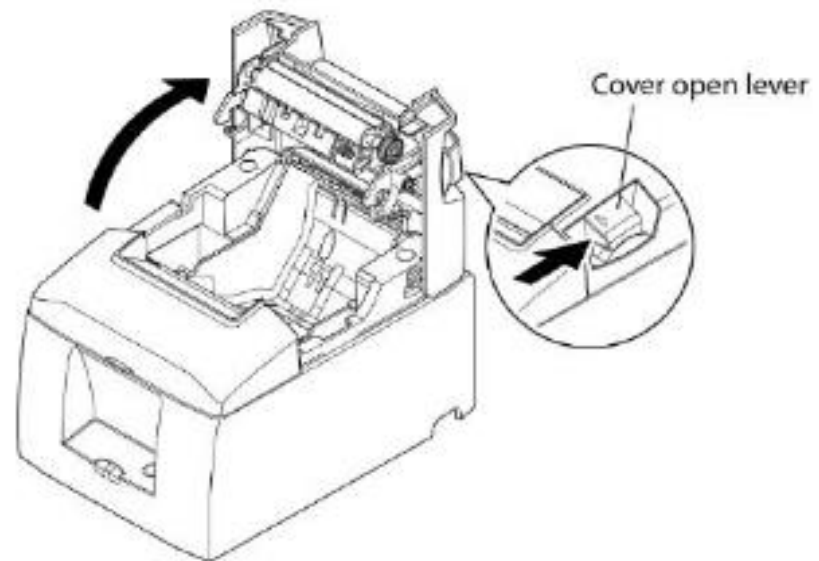

# CHANGING PAPER ON THE PRINTER

**Step 2** - Release the leading edge of the new paper roll and place in the printer. The paper should feed under the roll and then up towards the top of the printer. Pull the leading edge of the paper towards you and close the cover.

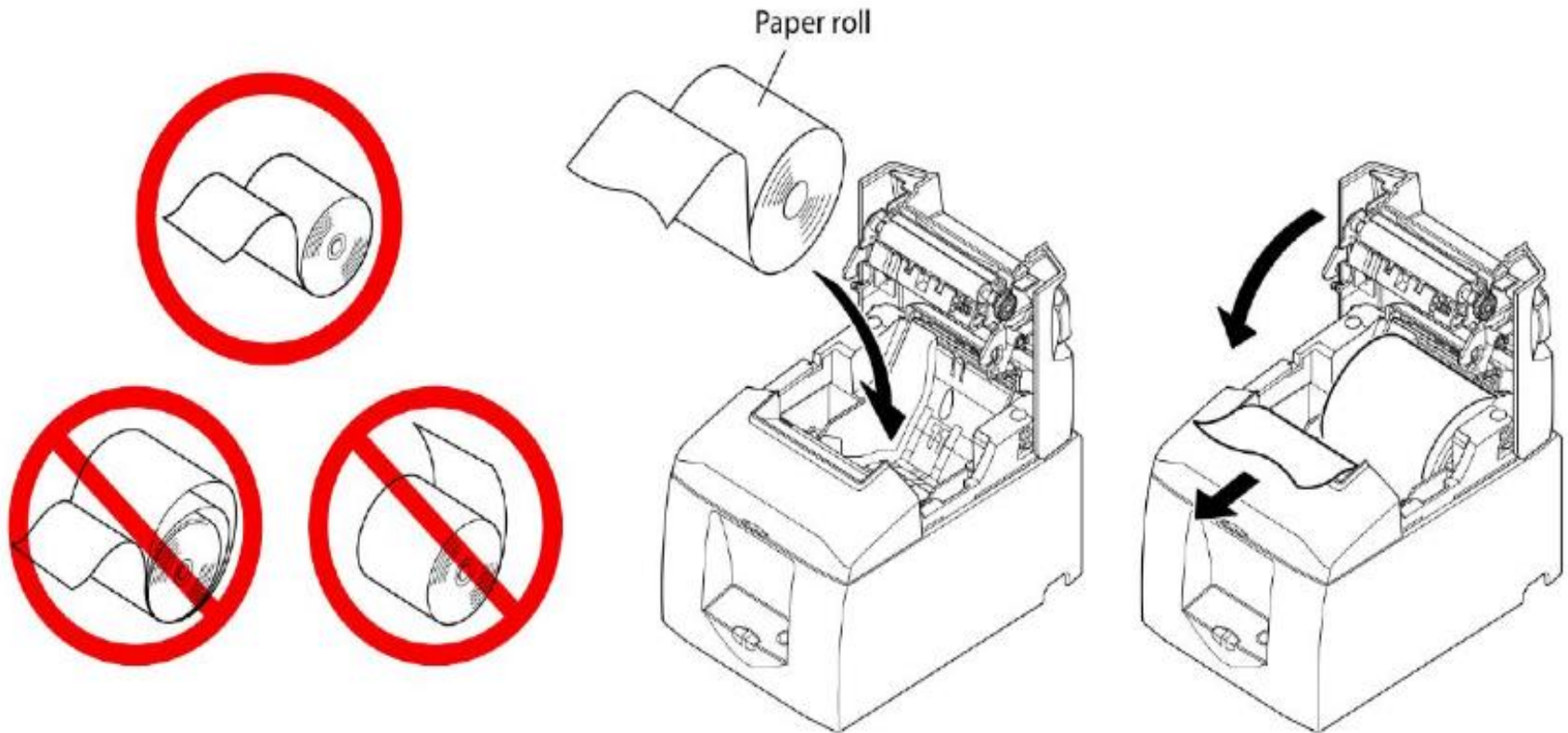

# POLL PAD SETUP

## UNPACKING THE IPAD



1. IPAD
2. IPAD STAND
3. ID TRAY
4. 2 STYLUS PEN
5. PLUGS AND WIRE



# TURNING ON THE HOTSPOT/JET PACK

## SETTING UP THE VERIZON JETPACK HOTSPOT



Connected Device Counter

Signal Strength

When connected, the Hotspot display will look a lot like a cell phone display. Make sure the hotspot has a good signal. If not, try moving it to a different location in the room, perhaps near a window. The hotspot will work reliably within 80' +/- of the Poll Pads.

Tap the **Power Button** to "wake up" the Hotspot screen if you need to confirm connectivity during the day.

# POLL PAD SETUP

**TURN ON  
THE IPAD**

**PRESS THE HOME  
KEY TO UNLOCK**

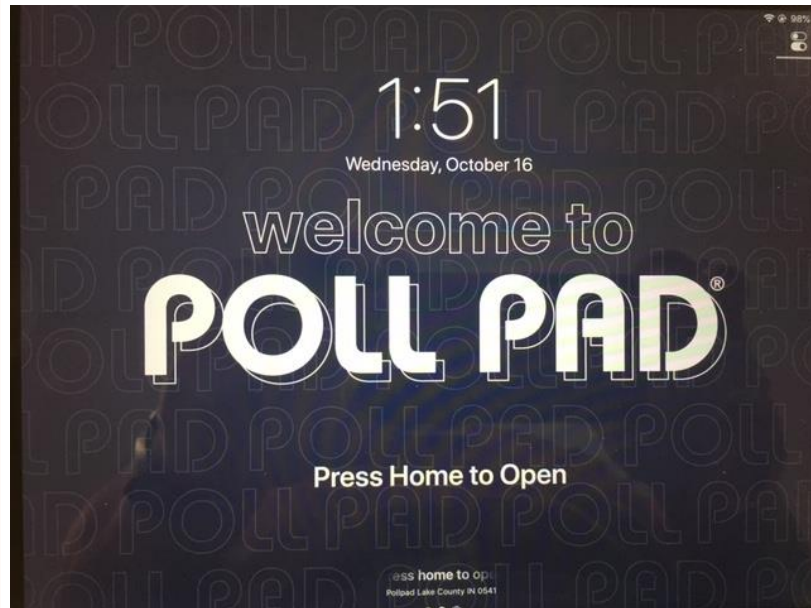

**POLLWORKER LOGIN:  
USER NAME  
AND PASSWORD WILL BE  
INCLUDED IN THE INSPECTOR  
KIT IN THE ENVELOPE WITH  
POLL WORKERS NAMES**

# POLL PAD SETUP

## USER NAME AND PASSWORD

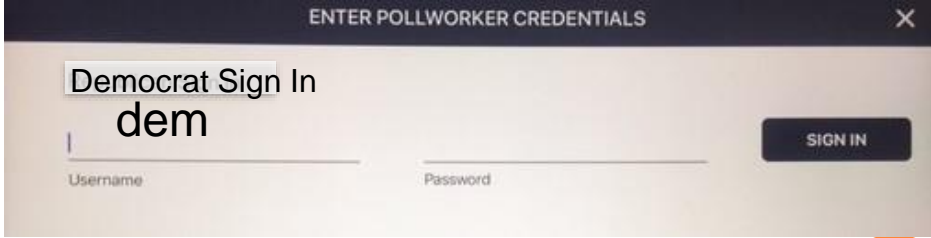
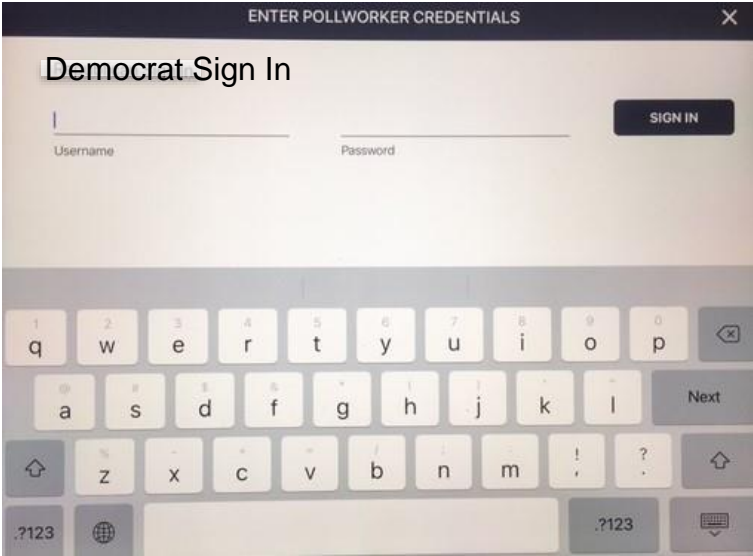
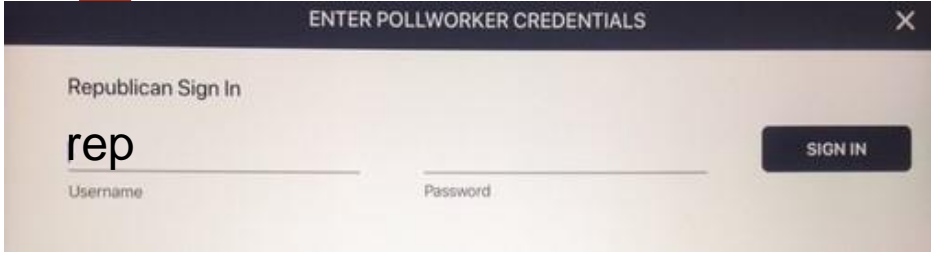
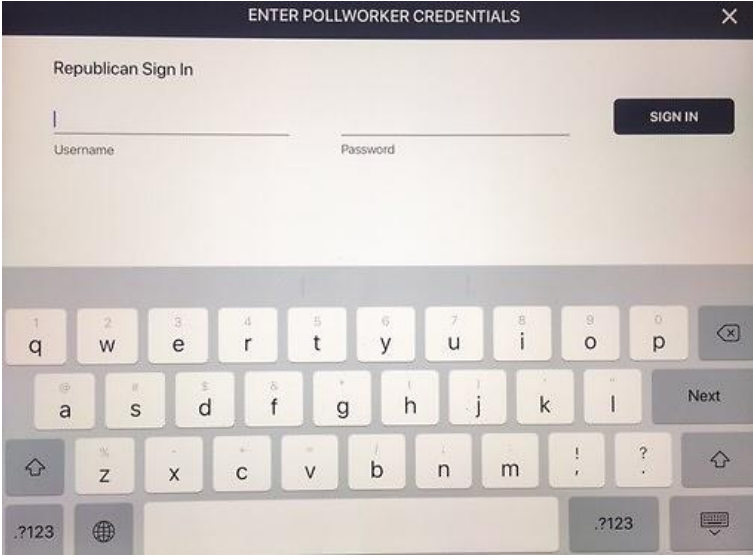

# POLL PAD

## VERIFY YOUR CHECK-IN COUNT IS AT ZERO



Lake County  
Training Location

Precinct Records: 354393

Checkins: 0

Countywide Records: 354393

Config. Profile: General - Encoding

LAKE COUNTY

Training Election – *“Election Year”*  
*“Day of Election”*  
*“Precinct Location”*

GET STARTED

# POLL PAD

## SCANNING THE BARCODE

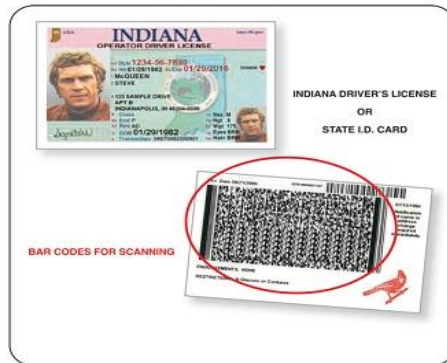

1. Ask the voter for their Photo ID and inspect it to ensure it meets voting standards.
2. If it is an Indiana Driver's License or Photo ID, place it in the ID tray with the barcode facing the camera, then tap "Scan Barcode."
3. Once scanned, the pad should take you directly to the Address Confirmation page for the voter. (If the pad gives you a list of voters, locate the correct one and tap on it to bring you to this page.)



# POLL PAD

## SCANNING THE BARCODE

Indiana County  
Butterfly House

GO BACK

Has the Voters Address Changed?

**Jacobs, Jason A**  
06/19/1983  
[REDACTED]  
Precinct 101, Split 001

Verify the Voters Address Above.

Has the Voters Address Changed?

ADDRESS UNCHANGED

ADDRESS CHANGED

1. Ask the voter if the address on the Poll Pad is correct. If so, choose “ADDRESS UNCHANGED” to move forward to the Voter Confirmation page.
  - a. IF the voter has moved or changed their name, choose “ADDRESS CHANGED.” The Poll Pad will then notify you the voter will need to complete the VRG 4/12 form and a VRG-11 form to update their information after the election. Choose “Continue” on this page to advance to the Voter Confirmation page.

# POLL PAD

## SCANNING THE BARCODE

1. On the Voter Confirmation page, select “Accept” in the top right corner to move forward.

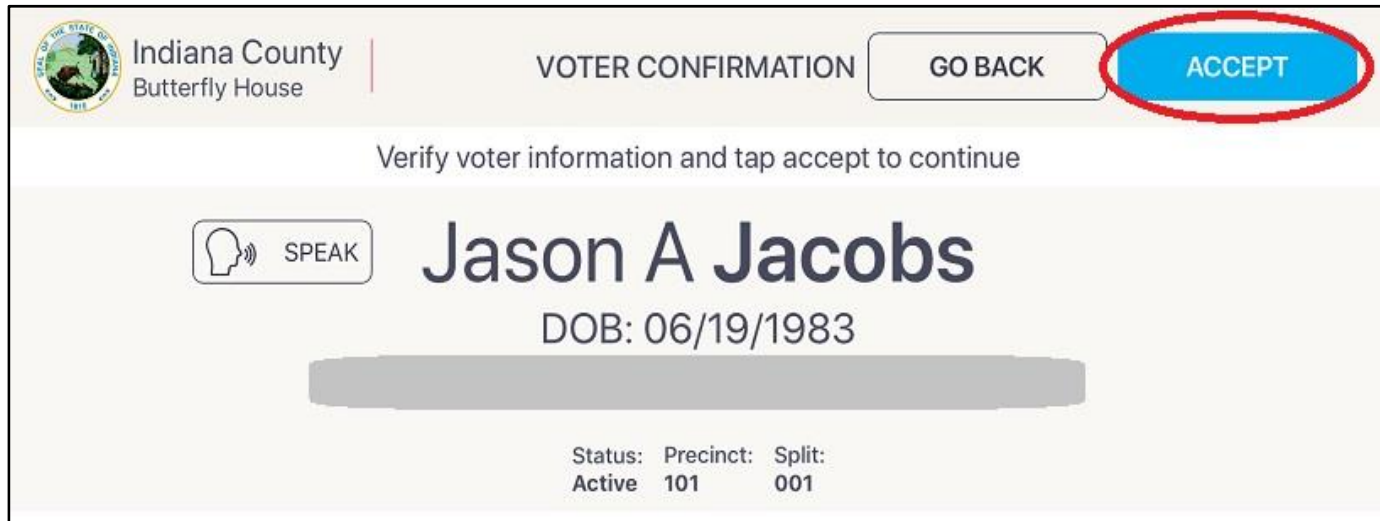

The screenshot shows the 'Voter Confirmation' page for Jason A Jacobs. The page header includes the Indiana County Butterfly House logo and the text 'Indiana County Butterfly House'. The main heading is 'VOTER CONFIRMATION'. There are two buttons: 'GO BACK' and 'ACCEPT'. The 'ACCEPT' button is highlighted with a red oval. Below the heading, it says 'Verify voter information and tap accept to continue'. The voter's name 'Jason A Jacobs' and 'DOB: 06/19/1983' are displayed. There is a 'SPEAK' button with a speaker icon. A grey bar obscures some information. At the bottom, there is a table with the following data:

Status:	Precinct:	Split:
Active	101	001

# POLL PAD

## SCANNING THE BARCODE

### VOTER MUST SELECT PARTY AFFILIATION

For Primary Elections, Turn the Poll-Pad to the Voter and allow the Voter to select their Party Affiliation by tapping the button only one time. The voter will then select “Accept”.



The screenshot shows a mobile application interface for party selection. At the top left is the Indiana County Butterfly House logo. The title "PARTY SELECTION" is centered at the top. To the right are "GO BACK" and "ACCEPT" buttons. Below the title is the instruction "Choose your party and tap Accept button to continue." At the bottom are two buttons: "Democratic" (highlighted in dark blue) and "Republican" (white with a grey border).

1. The Voter will then Sign the Poll-Pad and affirm his or her selection to the prior page is correct. The Voter will then select “Done Signing.”

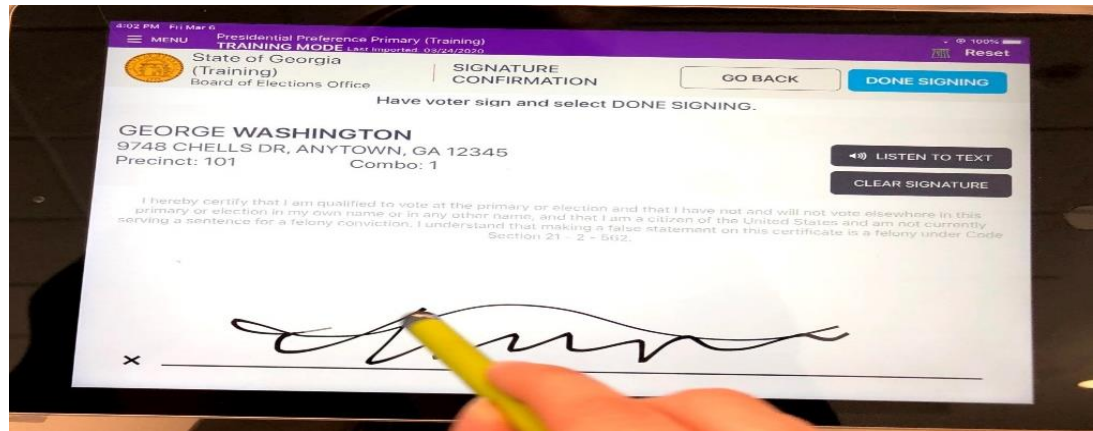

2. Turn the Poll Pad back to you (the Clerk) and compare the voter signature from the Poll Pad with the one on file then select “Submit” to complete processing of the voter.

Indiana County  
Butterfly House

POLL WORKER CONFIRMATION

START OVER SUBMIT

CONFIRM THE VOTER'S INFORMATION

Jason A Jacobs

Precinct: 101 DOB: 06/19/1983  
Split: 001  
Status: Active

Signature on File

Signature on Election Day

Ballot Style: 101 001 DEM

1. You will receive confirmation that the voter has been processed, and a voter slip will generate from the Bluetooth Printer. Give this slip to the Poll Judge, who will accompany the voter to the voting booth.

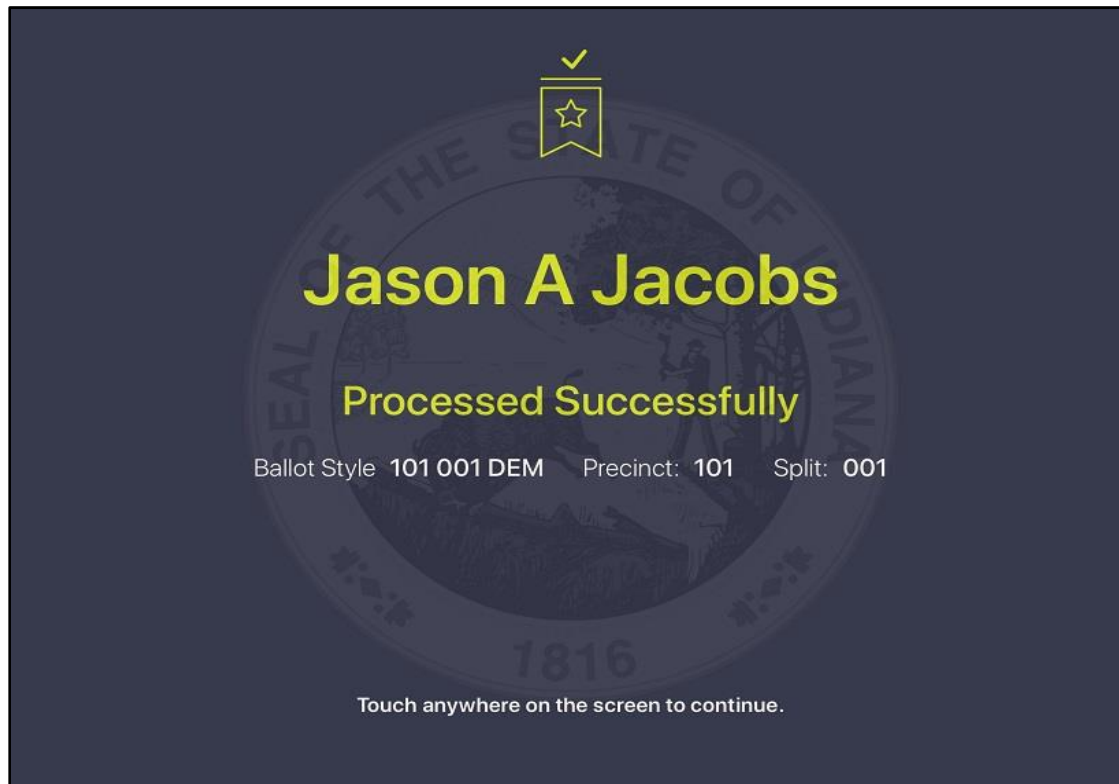

# POLL PAD

## MANUAL SEARCH

For voters with a Passport or Military ID (or the license does not scan, you can perform a Manual Search by selecting that button from the Main Screen.

You may enter a few letters of the voter's last name, then a few letters of the first name, then press "Search" to bring up all matching options. You can then scroll the screen upwards to find the voter match. Tap on the voter's name to advance to the Address Confirmation screen.

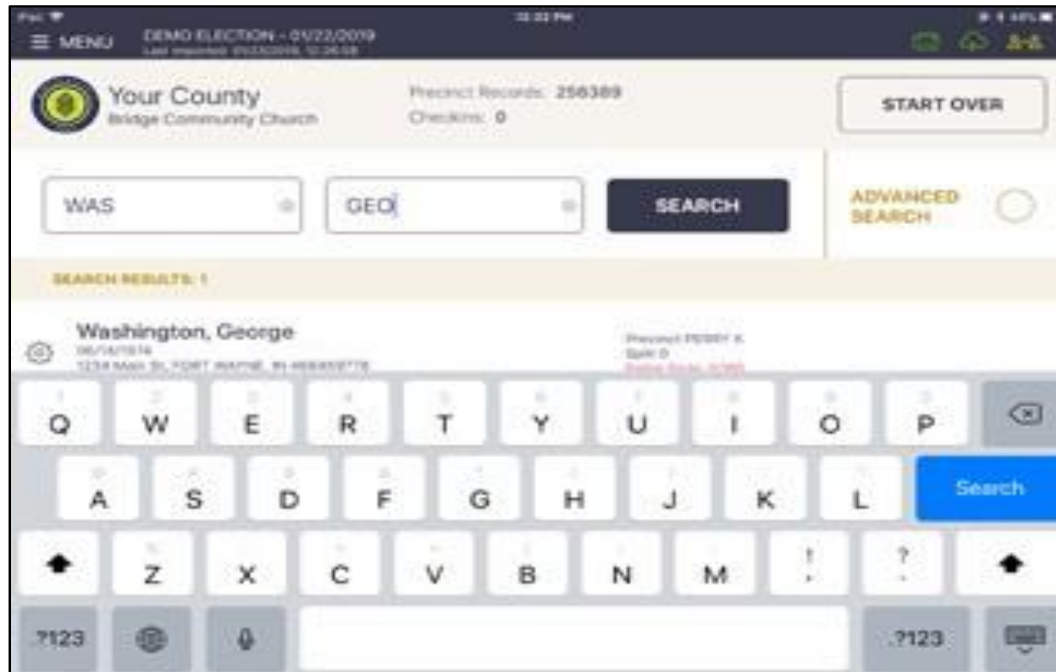

On the Manual Search screen, you may also select “Advanced Options” and choose to enter other information, such as Date Of Birth to further narrow down the options to find the correct voter.

The screenshot shows the Clay County Manual Search interface. At the top left is the Clay County logo and text: "Clay County", "Clay Community Schools", and "Central Office". To the right, it displays "Precinct Records: 18631" and "Checkins: 0". A "START OVER" button is in the top right. Below this are two input fields for "Last Name" and "First Name", followed by a "Search" button and an "ADVANCED OPTIONS" button. Underneath is a table with columns: "DOB", "ADDRESS", "LICENSE NO.", "VOTER ID", "PRECINCT CODE", "STATUS", and "RESET". The "DOB" field is currently empty and shows a date selection interface with "00 / 00 / 0000" and labels "MONTH", "DAY", and "YEAR". A "CLEAR" button is next to the date input. A close button (X) is also visible in the top right of the date selection area.

**IF YOU CANNOT LOCATE A VOTER ON THE POLL PAD,  
CONTACT YOUR COUNTY OFFICE FOR GUIDANCE.**

When a voter is found, please follow pages 52 to 56.

# **THE HELP AMERICA VOTE ACT**

**Is a Federal Law requiring each polling place to be accessible to elderly voters and voters with disabilities.**

- 1. Polling places should have accessible parking and obstructions to entrances should be removed.**
- 2. Poll workers should never assume a voter wants assistance.**
- 3. Be aware that dogs assisting people with disabilities must be admitted into the polling place.**

**PEOPLE WITH DISABILITIES CAN BRING SOMEONE TO THE POLLS TO ASSIST THEM IN THE VOTING BOOTH, OR THEY MAY REQUEST THE BIPARTISAN JUDGES TO ASSIST THEM (FORM PRE-3)**





**AFFIDAVITS OF VOTER ASSISTANCE**State Form 28192 (R9 / 11-15)  
Indiana Election Division (IC 3-11-9-2, 3-11-9-3)**(PRE-3)****INSTRUCTIONS:** Complete PART A or PART B – **NOT BOTH**. Return completed form in PRE-15 envelope.

<b>PART A</b>		<b>AFFIDAVIT OF PERSON DESIGNATED TO ASSIST A VOTER</b>
<b>A</b>	<b>INSTRUCTIONS:</b>	1. This affidavit must be completed BEFORE the voter enters the voting booth at the polls or to cast an absentee ballot.
<b>A</b>		2. The person who has been designated by a voter to assist the voter in the voting booth because of a disability (or the voter's inability to read or write English) must sign the affidavit.
<b>A</b>		3. The voter may designate a person of voter's choice, other than the voter's employer, an officer of the voter's union, or an agent of the voter's employer or union.
<b>A</b>		4. The precinct election board will keep this affidavit and return it with the other election supplies at the end of the day.
<b>A</b>		State of Indiana, _____ County:
<b>A</b>		I, the undersigned, affirm that to the best of my knowledge, the voter, _____, whom I assist in voting:
<b>A</b>		<i>(Name of Voter)</i>
<b>A</b>		1. Is a voter with a disability as defined in IC 3-5-2-50.2 (or is unable to read or write English); and
<b>A</b>		2. Has requested my assistance in voting at this election.
<b>A</b>		<b>NOTE:</b> This must be subscribed and sworn to before a person authorized to administer oaths within Indiana, such as the precinct inspector.
<b>A</b>	Signature of Person Assisting Voter	Printed Name of Person Assisting Voter
<b>A</b>	Subscribed and sworn to before me, this _____ day of _____, 20_____.	
<b>A</b>	Signature of Person Administering Oath	Title
<b>PART A</b>	<b>IF THIS SECTION HAS BEEN FILLED OUT, DO <u>NOT</u> FILL OUT PART B.</b>	
<b>PART B</b>		<b>AFFIDAVIT OF THE TWO JUDGES ASSISTING A VOTER</b>
<b>B</b>	<b>INSTRUCTIONS:</b>	1. This affidavit must be completed and signed by the two (2) election judges BEFORE the voter enters the voting booth at the polls.
<b>B</b>		2. The judges may assist any voter in marking the voter's ballot if the voter does not wish to designate a person of the voter's choice to assist the voter.
<b>B</b>		3. Only those voters who require assistance because of a disability (or the voter's inability to read or write English) may be assisted by the judges in the voting booth.
<b>B</b>		4. The precinct election board will keep this affidavit and return it with the other election supplies at the end of the day.
<b>B</b>		State of Indiana, _____ County:
<b>B</b>		I, the undersigned, affirm that to the best of my knowledge, the voter, _____, whom I assist in voting:
<b>B</b>		<i>(Name of Voter)</i>
<b>B</b>		1. Is a voter with a disability as defined in IC 3-5-2-50.2 (or is unable to read or write English);
<b>B</b>		2. Has requested my assistance in voting at this election; and
<b>B</b>		3. Does not wish to designate a person to assist the voter in voting under IC 3-11-9-2.
<b>B</b>		<b>NOTE:</b> This must be subscribed and sworn to before a person authorized to administer oaths within Indiana, such as the precinct inspector.
<b>B</b>	Signature of Judge	Printed Name of Judge
<b>B</b>	Signature of Judge	Printed Name of Judge
<b>B</b>	Subscribed and sworn to before me, this _____ day of _____, 20_____.	
<b>B</b>	Signature of Person Administering Oath	Title
<b>PART B</b>	<b>IF THIS SECTION HAS BEEN FILLED OUT, DO <u>NOT</u> FILL OUT PART A.</b>	



# **PRECINCT POLL INSPECTORS**

## **THE INSPECTOR MANAGES THE POLLING PLACE**

**The inspector shall ask voters to provide photo ID.**

**Challenge voters and accept challenges.**

**The inspector picks up election supplies on the Saturday prior to election.**

**The inspector administers the oath to all poll workers (PRE-1, Lavender Precinct Oath Book)**

**The inspector announces the opening and closing of the polling place.**

**Accompanied by the judge of the opposite political party, the inspector returns all election supplies at the drop off site.**

**The Inspector makes sure the CERTIFICATE OF EXPENSE is filled out and signed by the Poll Workers.**

NO ONE IS ALLOWED IN POLLING  
PLACE WITHOUT CREDENTIALS



# WHO IS ALLOWED IN THE POLLING PLACE WITH CREDENTIALS

STATE OF INDIANA }  
COUNTY OF LAKE } ss:

## Board of Election Commissioners

Date

5/7/2024

..... is hereby appointed to serve as

Deputy Election Commissioner

Voting Machine Mechanic

Member Absent Voter Traveling Board

Special Messenger

Courier / Counter

Election Board Member

Primary

and is to be admitted to any polling place for the  
Election.

I, ..... do solemnly swear that I will  
support the Constitution of the United States of America and the Constitution of the  
State of Indiana, and that I will faithfully, honestly and impartially discharge my  
duties in connection with the Elections, to the best of my skill and ability, So Help  
Me God.

Subscribed and sworn to before me this.....day of..... 20.....

Notary

# WHO IS ALLOWED IN THE POLLING PLACE ?

**Voters casting ballots (and children under 18 with the voter). Precinct election officials (inspectors, judges, poll clerks...). An individual authorized to assist a voter in voting. (Can not be a union rep, or the voter's employer).**

**If the voter requests assistance, but does not designate someone to help them, both Judges must accompany the voter into the voting booth and assist the voter.**

**● A person providing assistance to a voter (including Judges), must complete the Affidavit of Voter Assistance (PRE-3), before entering the voting booth.**

# PARTY WATCHERS, POLL BOOK HOLDERS, CHALLENGERS AND PEOPLE WITH MEDIA CREDENTIALS. DESCRIPTIONS DUTIES/RULES FOR EACH ARE FOUND IN THE 2024 INDIANA ELECTION DAY HANDBOOK

## Democrat Credentials

<b>DEMOCRAT POLL BOOK HOLDER'S CREDENTIAL I.C. 3-6-7</b>	
NAME AND ADDRESS OF POLL BOOK HOLDER	PRECINCT NUMBER
<b>DEMOCRAT PARTY CHALLENGER'S CREDENTIAL IC 3-6-7</b>	
NAME AND ADDRESS OF PARTY CHALLENGER	PRECINCT NUMBER
<b>DEMOCRAT WATCHER'S CREDENTIAL I.C. 3-6-8</b>	
NAME AND ADDRESS OF WATCHER	PRECINCT NUMBER

## Republican Credentials

<b>REPUBLICAN POLL BOOK HOLDER'S CREDENTIAL I.C. 3-6-7</b>	
NAME AND ADDRESS OF POLL BOOK HOLDER	PRECINCT NUMBER
<b>REPUBLICAN PARTY CHALLENGER'S CREDENTIAL IC 3-6-7</b>	
NAME AND ADDRESS OF PARTY CHALLENGER	PRECINCT NUMBER
<b>REPUBLICAN WATCHER'S CREDENTIAL I.C. 3-6-8</b>	
NAME AND ADDRESS OF WATCHER	PRECINCT NUMBER



# NEW 2024 POLLWORKER PAY SCALE

<b>2024 POLLWORKER PAY SCALE</b>				
<b>POSITION</b>	<b>BASE PAY</b>	<b>TRAINING</b>	<b>Republican Judge Assist Inspector to Drop-Site</b>	<b>TOTAL</b>
<b>INSPECTOR</b>	<b>210</b>	<b>30</b>		<b>240</b>
<b>DEM JUDGE</b>	<b>145</b>	<b>30</b>		<b>175</b>
<b>REP JUDGE</b>	<b>145</b>	<b>30</b>	<b>25</b>	<b>200</b>
<b>CLERKS</b>	<b>145</b>	<b>30</b>		<b>175</b>

**IF THE REPUBLICAN JUDGES RETURN THE ELECTION SUPPLIES WITH THE INSPECTOR AND SIGNS THE RETURN SHEET, THEY WILL RECEIVE AN ADDITIONAL \$25 IN PAY**



# STATEMENT OF EXPENSE

Township or Ward \_\_\_\_\_ Precinct \_\_\_\_\_

**LS 01**

## STATEMENT OF EXPENSE OF ELECTION BOARD AND OFFICERS FOR MAY ELECTION, MAY 4, 2010

**NOTE:**

1. Each board member and officer must fully complete the appropriate portions of this form.
2. PLEASE PRINT all information requested. Inspector: include name and address of polling place.
3. Federal Law requires that we report election workers compensation each calendar year.
4. File this statement with the Auditor in care of the Lake County Election Board at the same time the election returns are made.

**PLEASE PRINT**

	TRAINING	BASE AMOUNT	TOTAL	VARRAZIT NUMBER
INS REC: Name X _____ Soc. Sec.# _____ - - - - - Phone _____ Address _____ Zip Code _____		\$150.00*		
DEM JUDGE: Name X _____ Soc. Sec.# _____ - - - - - Phone _____ Address _____ Zip Code _____		\$100.00*		
REP. CLERK: Name X _____ Soc. Sec.# _____ - - - - - Phone _____ Address _____ Zip Code _____		\$50.00*		
REP. CLERK: Name X _____ Soc. Sec.# _____ - - - - - Phone _____ Address _____ Zip Code _____		\$100.00*		
Name X _____ Soc. Sec.# _____ - - - - - Phone _____ Address _____ Zip Code _____				
Name X _____ Soc. Sec.# _____ - - - - - Phone _____ Address _____ Zip Code _____				
Name X _____ Soc. Sec.# _____ - - - - - Phone _____ Address _____ Zip Code _____				
		\$50.00*		
		<b>Total</b>		

**PLEASE PRINT ALL INFO CLEARLY INCLUDING CITY AND ZIP CODE**

**PLEASE CHECK HERE IF YOU ATTENDED A TRAINING SESSION**

**POLLING PLACE INFORMATION**

**SIGN YOUR NAME HERE**

INSPECTOR  
 DEMOCRAT CLERK  
 REPUBLICAN CLERK  
 REPUBLICAN JUDGE

**All Members of the Board MUST Sign above or Checks will not be Issued.**

**INSPECTORS SIGN HERE ALSO**

I have examined this claim and hereby certify that it is a true and correct statement of the expenses incurred by me.

APPROVED BY THE STATE BOARD OF ACCOUNTS FOR LAKE COUNTY 2009.





CHECKS WILL BE  
MAILED ON  
June 13, 2024

990012100 41196 Salaries ..... \$ \_\_\_\_\_

990012100 43796 Rent ..... \$ \_\_\_\_\_

Vendor No. \_\_\_\_\_  
IN FAVOR OF \_\_\_\_\_  
(Print) Inspector's Name \_\_\_\_\_  
Address \_\_\_\_\_  
City State Zip \_\_\_\_\_  
Pct. No. \_\_\_\_\_

I have examined this claim and certify as follows:

That it is in proper form,

That it is duly authenticated as required by law.

That it is based upon contract  
statutory authority

That it is apparently correct  
incorrect

\_\_\_\_\_  
County Auditor

On Account of Primary Election May 3, 2011

Allowed..... 2011

In the sum of \$ \_\_\_\_\_

\_\_\_\_\_  
Board of County Commissioners

Warrant No. \_\_\_\_\_ issued in payment

Filed ..... 2011

\_\_\_\_\_  
Auditor

10494

## STATEMENT OF EXPENSE

IF YOU DO NOT CORRECTLY FILL IN THE STATEMENT OF EXPENSE SHEET YOU WILL DELAY PAYMENT FOR ALL YOUR WORKERS.

DO NOT RELY ON THE INSPECTOR TO FILL OUT YOUR PAY INFORMATION. IT IS YOUR RESPONSIBILITY!

REMEMBER YOUR CHECKS ARE MAILED TO THE ADDRESS ON THE CLAIM

**FULL SS# REQUIRED NOT JUST LAST 4.**

## Proof of Residency Additional Documentation

*Who is required to show additional documentation, beyond a photo ID?*

- ✓ This requirement applies to voters who registered to vote by mail for the first time in Indiana
- ✓ If a voter is required to show additional documentation, this will be noted on the poll book

### **Examples of Acceptable Documents**

- ✓ Indiana Driver's License or ID card with current address=DL
- ✓ Current Utility Bill=UB                      Paycheck=PY
- ✓ Bank Statement=BY                              Government Document=GD
- ✓ Government Check=GV
- ✓ **IF VOTER HAS NO DOCUMENTATION AND/OR SIGNS POLL LIST, VOTER MUST VOTE PROVISIONAL BALLOT**

# AUDIT YOUR NUMBERS

## **THIS IS MANDATORY**

Using the PRE 16 form to audit your precinct

Note: discrepancies throughout the day, all discrepancies should be noted on the pre-16

Check the number of check-ins on the Poll pad, then ask the judge how many people have voted on the machines. Add the machine numbers together to see if they match the Poll Pad check-ins.

Write it down on the PRE-16 form. If they don't match, you'll need to find out why. Maybe you had someone leave without voting or someone voted Provisional. If so, please write why the numbers didn't match.



# PRE-16 PART 1



## INSPECTOR AND JUDGE'S REPORT OF TOTAL NUMBER OF VOTES CAST ON ELECTRONIC VOTING SYSTEMS IN PRECINCT / VOTE CENTER AND NUMBER OF VOTERS WHO RECEIVED BALLOT AT PRECINCT / VOTE CENTER AS INDICATED BY SIGNING POLL LIST OR EPOLLBOOK

(PRE-16)

State Form 50529 (R2 / 8-23)  
Indiana Election Division (IC 3-12-3.5-8(d))

**INSTRUCTIONS:** This form is used in a precinct / vote center that uses an electronic voting system. After the polls close, each electronic voting system in a precinct / vote center has been secured, and the paper vote total printouts have been obtained, the inspector and the judge of the opposite party shall record the number of votes cast on all electronic voting systems located within the precinct / vote center. Use the work sheet on the reverse side of this form.

The inspector and judge shall also record the number of voters who have received a regular ballot by signing in at the polls, according to the paper poll list or ePollbook for the precinct / vote center and shall determine if there is a difference between the two numbers. Voters receiving a provisional ballot should not be included in this total.

If there is a difference between the total number of votes cast on the electronic voting system and the number of individuals who signed the poll list, then the inspector and judge shall use this form to report the discrepancy to the county election board, including any reasons for the discrepancy, if known. The inspector and judge shall return this form to the county election board with the certificates stating the total number of votes that each candidate received for each office and the votes on each public question.

### REPORT OF DISCREPANCY BETWEEN THE NUMBER OF VOTES CAST IN THE PRECINCT / VOTE CENTER AND THE NUMBER OF VOTERS WHO RECEIVED A BALLOT FOR THIS PRECINCT / VOTE CENTER, ACCORDING TO THE POLL LIST OR EPOLLBOOK

Precinct, if applicable: \_\_\_\_\_ Name of Polling Location or Vote Center: \_\_\_\_\_

To the \_\_\_\_\_ County Election Board:

We, the undersigned, report the following as required by Indiana Code 3-12-3.5-8:

- 1) We are the duly appointed and acting inspector or judge [or judges] of the opposite political party from the inspector, or are designated under the county voter center plan to perform the duties of the inspector or judge of the precinct polling location or vote center named above.
- 2) Based on the vote total printouts for each electronic voting system used in the precinct / vote center, the total number of votes cast on all electronic voting systems is \_\_\_\_\_.
- 3) Based on the poll list OR electronic poll book (ePollbook) for this precinct / vote center, the number of voters who received a regular ballot for this precinct / vote center is \_\_\_\_\_. *Do not include provisional ballot voters in this total.*
- 4) The discrepancy between the number in (2) and the number in (3) is \_\_\_\_\_.
- 5) The reasons for this discrepancy, if known, are set forth on the reverse of this form.

SIGNED, THIS THE \_\_\_\_\_ DAY OF \_\_\_\_\_, 20 \_\_\_\_\_:

\_\_\_\_\_  
Signature of Inspector

\_\_\_\_\_  
Printed Name of Inspector

\_\_\_\_\_  
Signature of Judge of Opposite Party

\_\_\_\_\_  
Printed Name of Judge of Opposite Party

**If additional Judges of the Opposite Political Party are completing this report, insert the printed names and signature of those individuals below:**

\_\_\_\_\_  
Signature of Judge of Opposite Party

\_\_\_\_\_  
Printed Name of Judge of Opposite Party

\_\_\_\_\_  
Signature of Judge of Opposite Party

\_\_\_\_\_  
Printed Name of Judge of Opposite Party



# PRE-16 PART 2

	Votes Cast on Electronic Voting System		Electronic or Paper Poll Lists – Voters Receiving Ballots*	
	Machine Number	Number of Voters	Precinct Name or ePB Number	Number of Voters
1.				
2.				
3.				
4.				
5.				
6.				
7.				
8.				
9.				
10.				
11.				
12.				
13.				
14.				
15.				
<b>Total</b>				

Machine Number may be the precinct assigned to the voting system, may be an asset tag used by the county, or another tracking method. If using a paper poll list, the name may be the name of the precinct. If using an ePollbook, the name may be the precinct, asset tag number, or another tracking method used by the county. Please contact your county election board for more instruction.

*\*Do not include provisional ballot voters who signed the poll list in this number!*

### **DISCREPANCIES OR PROBLEMS**

*Please describe in detail any discrepancies or problems, such as the use emergency ballots, voting system and others specifying the **voter's' individual precinct.***

**DOCUMENT THESE DISCREPANCIES OR PROBLEMS AS THEY OCCUR BELOW.**

---

---

---

---

---

---

---

---

---

---

---

---

---

---

---

---

---

---

---

---

---

---

---

---



# THE ONE WHO GOT AWAY

When a Voter leaves the booth without “casting” their ballot, The Poll Workers must attempt to alert the Voter. If unable to do so, or the Voter declines to return, the Inspector and BOTH Judges must complete the process by pressing the “CAST VOTE” button.

There is a new form in your Inspector booklet (**PRE-9**) that must be signed to document this occurrence by the Inspector and Judges.



# FOR E-POLL PAD ERRORS ONLY

An individual who knowingly makes a false statement by signing a poll list or by falsely indicating the individual's name, voter ID #, or residence address commits a Level 6 Felony as provided by IC3-14-2-11.

VOTER'S POLL LIST: 2019 PRIMARY ELECTION

LAKE COUNTY

PRECINCT #

NAME OF VOTER	PARTY	SIGNATURE OF VOTER	ADDRESS OF VOTER	DOB	DL#/LAST 4 SSN	REASON
Joel Rodriguez			5555 Northcote Ave	12/23/71	2222	not in IPad





# THE ONE WHO HAD TO WAIT

## LONG LINES

There's another new form where the Inspector needs to write down how many voters were in line at: 6:00 a.m., 12:30 p.m. and 6:00 p.m.

It is Step 6 and it will be found in in your Inspector Booklet.

Make sure you fill it out!!

(PRE-1, INSPECTOR OATH BOOK), STEP 6



# VALID ID'S FOR VOTING PURPOSES IN INDIANA

**YES**

**These ID'S ARE VALID** for voting purposes in Indiana.

**PHOTO ID MUST MEET 4 CRITERIA TO BE ACCEPTABLE FOR VOTING PURPOSES. IT MUST:**

1. Display the voter's photo
2. Display the voter's name, and the name must conform to the voter registration record
3. Display an expiration date and either be current or have expired sometime after the date of the last General Election **11/8/2022**
4. Be issued by the State of Indiana or the U.S. government
5. **POLL WORKER SHOULD NOT BE CHECKING FOR ADDRESS**

Office of the Indiana Secretary of State [www.in.gov/sos](http://www.in.gov/sos)

# THESE ID'S ARE NOT VALID FOR VOTING PURPOSES IN INDIANA

**NO**



These ID'S ARE NOT VALID for voting purposes in Indiana

A photo ID must meet 4 criteria to be acceptable for voting purposes. It must:

- 1 Display the voter's photo
- 2 Display the voter's name, and the name must conform to the voter registration record
- 3 Display an expiration date and either be current or have expired sometime after the last General Election **11/8/2022**
- 4 Be issued by the State of Indiana or the U.S. government

## Photo ID Law

### *What are the requirements under the Photo ID Law?*

1. Voter's photo must be displayed on the ID
2. Voter's name on the ID must conform to the name on the poll book
3. Expiration date (current or expired after the date of the last General Election; expiration dates of INDEF also work) **11/8/2022**
4. Issued by the State of Indiana or the US government

***Poll worker should NOT be checking for address***

## Photo ID "Conform" Example

- ✓ The voter's name on the Photo ID must conform to the name on the voter registration record
- ✓ People commonly use nicknames, middle names, and initials as a substitute for their given first name
  - Robert John Crew
  - Robert J. Crew
  - Robert Crew
  - R. John Crew
  - R. J. Crew
  - Bob John Crew
  - Bob J. Crew
  - Bob Crew
  - John Crew
  - J. Crew

***Conform does NOT mean it needs to match identically***

# SPLIT PRECINCTS

HERE IS A SAMPLE OF A SPLIT PRECINCT IN LAKE STATION

Note: There are split precincts in East Chicago, Gary, Lake Station, Lowell, and Merrillville

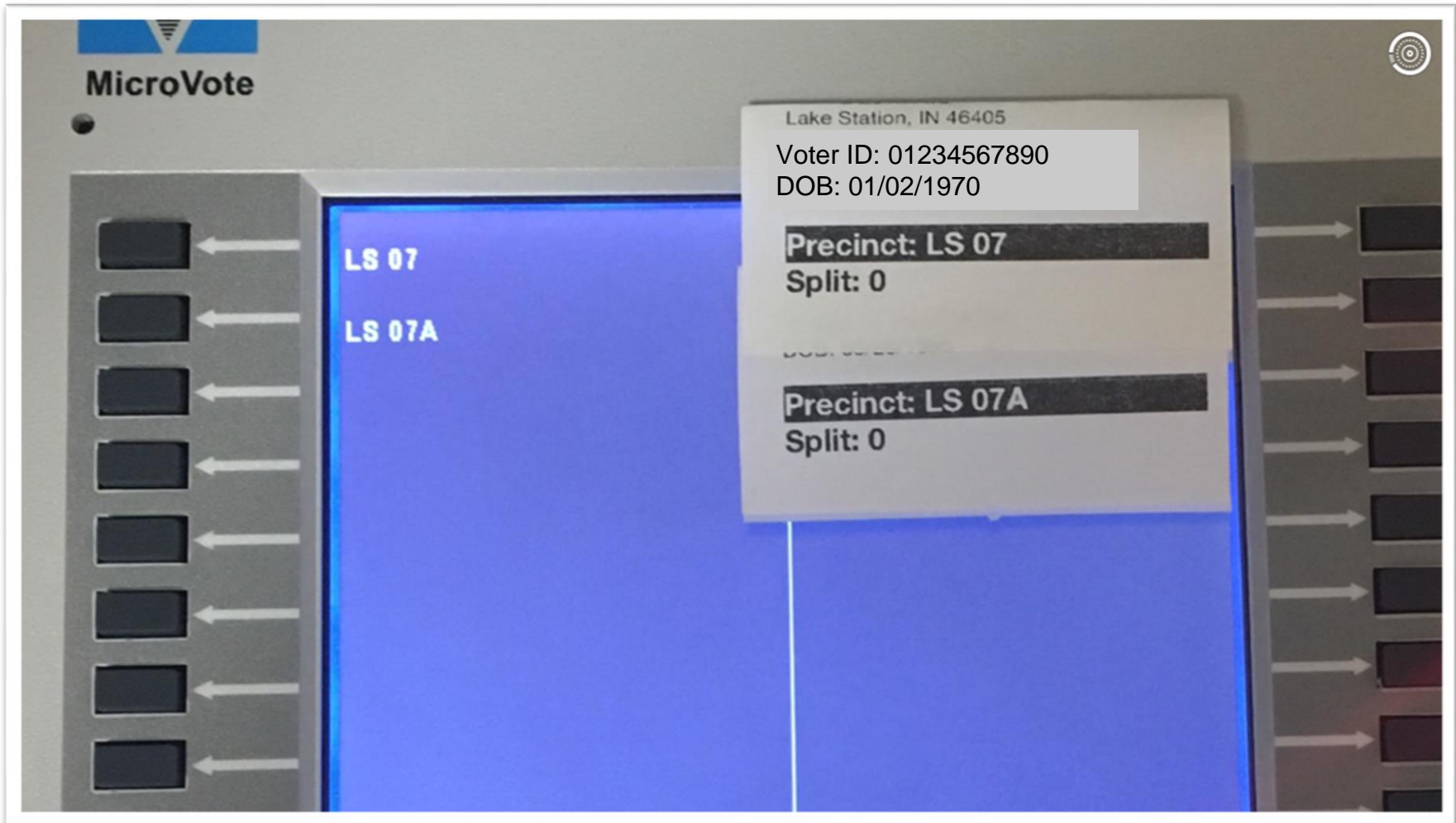



**VOTER'S AFFIDAVIT  
REQUESTING TO VOTE IN PERSON AT THE POLLS AFTER  
FAILING TO RECEIVE MAILED ABSENTEE BALLOT**

**(PRE-5)**

State Form 55876 (R / 10-15)  
Indiana Election Division (IC 3-11-10-31; 3-11.5-4-18(c))

**INSTRUCTIONS:** A voter who requested that an absentee ballot be mailed to the voter, but has not received the absentee ballot by election day, may vote in person at the polls upon executing this affidavit.

STATE OF INDIANA )  
 )  
COUNTY OF \_\_\_\_\_ )  
 ) **SS:**  
TOWNSHIP OR WARD \_\_\_\_\_ )  
 )  
PRECINCT \_\_\_\_\_ )

**VOTER'S AFFIDAVIT  
REQUESTING TO VOTE IN PERSON AT POLLS  
AFTER FAILING TO RECEIVE MAILED  
ABSENTEE BALLOT**

I, the undersigned, do solemnly swear all of the following:

- (1) I filed an application with the county election board (or county board of elections and registration) requesting that an absentee ballot be mailed to me for the election to be conducted today.
- (2) As of today, I have not received the absentee ballot requested in my application.
- (3) I request that I be permitted to vote in person at the polls in this election.

\_\_\_\_\_  
Signature of Voter

\_\_\_\_\_  
Printed Name of Voter

**SUBSCRIBED AND SWORN TO BEFORE ME, THE DULY ACTING \_\_\_\_\_ (insert title of  
precinct election official or vote center official) OF THIS PRECINCT, ON THIS  
THE \_\_\_\_\_ DAY OF \_\_\_\_\_, 20\_\_.**

\_\_\_\_\_  
Signature of Precinct Election Official  
(or Vote Center Official)

\_\_\_\_\_  
Printed Name of Precinct Election Official  
(or Vote Center Official)



The Lake County Board  
of Elections and Registration  
2293 North Main Street, A-205  
Crown Point, IN 46307-1854

© GCI 1049-M

This envelope contains blank absent voter's ballot (ABS-8)  
for the  Primary  General or Municipal  Special Election

(Insert date of election) **5/7/2024**  
and if not called for or delivered within 5 days, return to sender.

POSTAGE  
STAMP HERE  
(AT LEAST FIRST  
CLASS MAIL)

**Surrendered**

**NOTE! ALL MATERIALS ENCLOSED IN THE ABS-8 MUST BE  
SURRENDERED**



# Fail Safe Procedures

## What is a fail safe procedure?

- ✓ Fail safes are procedures in place to help resolve voter eligibility issues at the polls
- ✓ In Indiana, we try everything before issuing a provisional ballot
- ✓ **No one is ever turned away from the polls without receiving a ballot**

## They are...

### 1. Call the County Election Board for potential Certificate of Error or a Miscellaneous Error

- ✓ If the voter's name is not on the POLL-PAD due to a county error, write information on the EPoll-Pad Errors sheet. Which is on the very last page of the Forms Book

### 2. EMERGENCY LIST OF VOTERS

### 3. Use the VRG-4/12 Form

- ✓ If the voter has moved outside of the precinct but in the same city or town





# WHEN A CHALLENGE SHOULD BE ISSUED

It is against the law...

1. For a person who is not eligible to vote in the precinct to attempt to cast a ballot.
2. For a precinct election official to knowingly fail to challenge an ineligible person.
3. For a precinct election official to challenge a voter that the official knows is eligible to vote.

## **WHO MAY CHALLENGE A VOTER?**

1. Member of the Precinct Election Board
2. A poll clerk only based on questionable signature.
3. A challenger appointed by a political party/candidate with proper credentials.



# Inspectors

- IF YOU USE ANY PROVISIONAL BALLOTS OR EMERGENCY BALLOTS **(THE USE OF EMERGENCY BALLOTS REQUIRES PERMISSION! YOU MUST CALL 219-755-3795.)**

- YOU NEED TO SHOW THAT YOU USED THEM BY MARKING ENVELOPE #1 (WHITE ENV.) WHERE INDICATED 



# WHAT PROVISIONAL SUPPLIES GO TO THE PRECINCT?

- SEALED RED PROVISIONAL BAG
  - INSIDE BAG:
  - FORM BOOK
  - SECRECY ENVELOPES
  - BALLOT CARDS
  - OFFICIAL BALLOT
  - PRE-4 – PRO-2 ENVELOPE





**CHALLENGE AFFIDAVIT OF A VOTER BY A CHALLENGER OR MEMBER OF THE PRECINCT ELECTION BOARD / AFFIDAVIT OF A CHALLENGED VOTER**  
 State Form 42132 (R14 / 3-22)  
 Indiana Election Division (IC 3-11-8-21; 3-11-8-23.5; 3-11.5-4-13.5; 3-11.5-4-13.6)

(PRE-4)

Is this an absentee ballot?  Yes  No

**INSTRUCTIONS:** After the challenger completes this side of the form, the challenged voter may complete the second page of this form. If the challenged voter does so, the challenged voter is entitled to cast a provisional ballot. Do not use this form to challenge a voter at a primary election due to the voter's party affiliation. Use PRE-6 form instead.  
**NOTE: THIS FORM MUST BE PRINTED DIRECTLY ON THE PRO-2 PROVISIONAL BALLOT SECURITY ENVELOPE.**

STATE OF INDIANA, COUNTY OF \_\_\_\_\_

**GENERAL INFORMATION**

I, the undersigned, believe that \_\_\_\_\_, now offering to vote, is not a legal voter in this precinct, for the following reason(s):  
 (insert name of voter.)

- Voter Eligibility – Fall Safe Procedures**
- This voter's name is not included on the poll list, and is **NOT** entitled to vote by using a "Fall Safe" procedure.
  - This voter's name is included on the poll list, but this voter does not currently reside in the precinct, and is **NOT** entitled to vote in this precinct by completing a VRG-4/12 form or a VRG-15 form, or other "Fall Safe" procedure.
- Voter Identification**
- This voter was unable or declined to present proof of identification when required by law to do so.
  - This voter is identified on the poll list as required to present an additional document that confirms the voter's identity and current residence address, but has not done so.

**Voter Eligibility - General Requirements**

- This voter is not a U.S. citizen.
- This voter will not be eighteen (18) years of age or older at the general election.
- This voter's signature on the election day poll list does not match the signature on the voter's registration record.
- This voter's signature on the absentee ballot security envelope affidavit is missing or does not match the signature on the voter's absentee ballot application, electronic poll book, registration record maintained in the statewide voter registration system.
- Other \_\_\_\_\_  
 (insert specific reason for challenging voter.)

I obtained the information from \_\_\_\_\_  
 (insert name of person(s) supplying information for challenge.)

**CHALLENGER AFFIRMATION**

I swear (or affirm) that the foregoing statements are true, to the best of my knowledge and belief, and understand that making a false statement on this affidavit is punishable under the penalties of perjury.

Signature of challenger	Printed name	If serving as precinct officer: <input type="checkbox"/> Inspector <input type="checkbox"/> Judge <input type="checkbox"/> Poll Clerk
Precinct	Township or ward	City or town

**AFFIRMATION OF AFFIDAVIT**

STATE OF \_\_\_\_\_ )  
 )  
 COUNTY OF \_\_\_\_\_ )  
 )  
 I swear (or affirm) that the above challenge affidavit of a voter was subscribed and sworn to before me this \_\_\_\_\_ day of \_\_\_\_\_, 20\_\_\_\_.

Signature of Official Administering Oath (Inspector, Judge, Poll Clerk, Sheriff, or Absentee Board Member Other than Challenger above) \_\_\_\_\_ Printed Name and Title \_\_\_\_\_

**AFFIDAVIT OF A CHALLENGED VOTER**

STATE OF INDIANA, COUNTY OF \_\_\_\_\_

**GENERAL INFORMATION**

- I, the undersigned, state the following:
- that I am a citizen of the United States.
  - that my date of birth is \_\_\_\_\_ / \_\_\_\_\_ / \_\_\_\_\_ (mm/dd/yy) to the best of my information and belief.
  - that I have been a bona fide resident of this precinct for thirty (30) days immediately before this election or I am qualified to vote in this precinct under IC 3-10-10, IC 3-10-11, or IC 3-10-12.
  - that I am generally known by the name in which I desire to vote, which is \_\_\_\_\_.
  - that I have not voted and will not vote in any other precinct in this election.
  - that my present residence address is \_\_\_\_\_  
 (and, if applicable, my residence address thirty (30) days before this election was at: \_\_\_\_\_)  
 I moved to my residence address in this precinct on the following date: \_\_\_\_\_ / \_\_\_\_\_ / \_\_\_\_\_ (mm/dd/yy)
  - that, if applicable, if I was challenged under boxes 3 or 4 on the Affidavit of a Voter By a Challenger portion of this form, I did present proof of identification or additional documentation that complied with IC 3-5-2-40.5 or IC 3-7-33-4.5.

**CHALLENGED VOTER AFFIRMATION**

I swear (or affirm) that the foregoing statements are true, to the best of my knowledge and belief, and understand that making a false statement on this affidavit is punishable under the penalties of perjury.

Signature of challenged voter	Printed name
Precinct	Township or ward City or town

**AFFIRMATION OF AFFIDAVIT**

STATE OF \_\_\_\_\_ )  
 )  
 COUNTY OF \_\_\_\_\_ )  
 )  
 I swear (or affirm) that the above challenge affidavit of a voter was subscribed and sworn to before me this \_\_\_\_\_ day of \_\_\_\_\_, 20\_\_\_\_.

Signature of Official Administering Oath (Inspector, Judge, Poll Clerk, Sheriff, or Absentee Board Member Other than Challenger above) \_\_\_\_\_ Printed Name and Title \_\_\_\_\_

# PRE-4/PRO-2 ENVELOPE

**1. PERSON CHALLENGING COMPLETES TOP PORTION OF PRE-4 (USUALLY INSPECTOR OR CLERK)**

**2. CHALLENGED VOTER COMPLETES BOTTOM**



**4. IT IS MANDATORY THAT BOTH CLERKS MUST INITIAL THE BACK OF THE PROVISIONAL BALLOT CARD AND SECRECY ENVELOPE OR VOTE WILL NOT COUNT.**

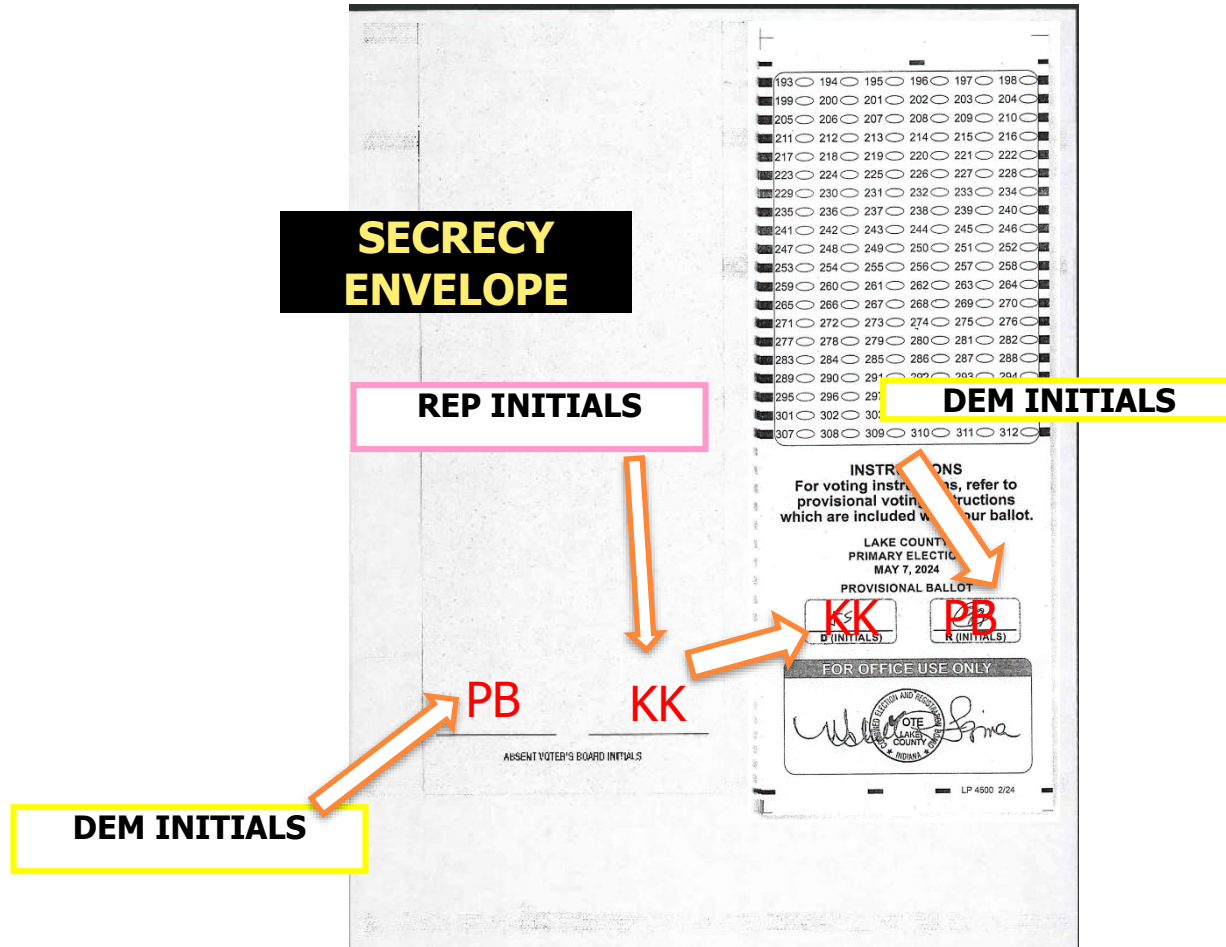

**5. GIVE VOTER THE PROVISIONAL BALLOT CARD, OFFICIAL BALLOT, SECRECY ENVELOPE AND THE SECURITY ENVELOPE ( PRO-2/PRE-4)**



# PRIOR TO VOTING

## VRG 4/12 FORM

**IF VOTER INFORMS THE CLERK THAT THEY HAVE MOVED, THE CLERK MUST FIRST VERIFY THAT THE VOTER HAS MOVED WITHIN THE SAME CITY/TOWN, then the voter must complete a VRG 4/12 and VRG-11. The voter can vote one last time in their old precinct**





**AFFIDAVIT OF REQUEST TO UPDATE VOTER REGISTRATION AT THE TIME OF REQUESTING A BALLOT**

(VRG 4/12)

State Form 28166 (R16 / 8-23)  
INDIANA ELECTION DIVISION (IC 3-7-39-7; 3-7-48-5; 3-10-1-24; 3-10-11-5; 3-10-12-3.4)

**INSTRUCTIONS**

Questions regarding when to use this form should be directed to the County Election Board at LAKE (insert telephone number.)

A description of the voters eligible to vote using this form is on the reverse side. A voter must complete and sign this form in front of a notary or other person authorized to administer oaths, which includes an Election Day precinct election officer, or before Election Day, an absentee voter board member. Alternatively, if Box 2, 3, 4 or 5 apply, the voter is permitted to make an oral affirmation to the poll workers or absentee voter board members, who will then record the voter's affirmation and initial below in the box designated for the voter to sign.

**VOTER AFFIRMATION**

To be eligible to vote using this form, a voter must make one of the affirmations below. To the County Election Board, Precinct Election Board, or Absentee Voter Board of LAKE County: I, the undersigned, affirm that the information on this affidavit is true and complete, to the best of my knowledge.

I am eligible to vote in this precinct as indicated above: (you must check either Box 1, 2, 3, 4, or 5)

- BOX 1: I changed my residence from one (1) precinct to another within Indiana less than 30 days before the primary/general/special election held on the \_\_\_\_\_ day of \_\_\_\_\_, 20\_\_\_\_; OR
- BOX 2: I changed my residence from one (1) precinct to another within the same county and within the same congressional district before the primary/general/special election held on the \_\_\_\_\_ day of \_\_\_\_\_, 20\_\_\_\_; OR
- BOX 3: In a county using an electronic poll book, I changed my residence from one (1) address to another address within the same precinct; OR
- BOX 4: In a county using an electronic poll book, I changed my name and desire to update my voter registration record; OR
- BOX 5: I still reside at the address indicated on my cancelled voter registration record despite the county indicating that I moved from my residence.

**VOTER'S NAME, DATE OF BIRTH, VOTER IDENTIFICATION NUMBER AND TELEPHONE NUMBER**

Last Name		First Name		Middle Name	Precinct
Date of Birth (mm/dd/yyyy)		Voter Identification Number			Telephone Number (optional)
____/____/____		<small>(Indiana issued driver's license number, OR state identification number, OR if voter does not possess driver's license, provide last 4 digits of social security number, OR state NONE if voter does not possess any of these documents)</small>			( )

Are you a citizen of the United States of America?  Yes  No Will you be at least eighteen (18) years of age on or before election day?  Yes  No

**VOTER'S PREVIOUS NAME (If voter's name has changed, complete this section with the voter's name before the voter changed it.)**

Last Name		First Name		Middle Name
-----------	--	------------	--	-------------

**VOTER'S PREVIOUS RESIDENCE ADDRESS (If voter checked BOX 1, 2, or 3 above)**

Street Address	City / Town	State	ZIP Code	County
		IN		

**VOTER'S CURRENT RESIDENCE ADDRESS (If voter checked BOX 1, 2, or 3 above)**

Address instructions: If residing in a city or town, write the street address and any apartment or room number. If not residing in a city or town, write the mailing address and the nearest streets or roads if not included. Example: "100 Maple Street, Apt. 12, Anytown, IN" or "R.R. 5, Box 12 (Invisible Road and County Road 100 North), Anytown, IN."

Street Address	City / Town	State	ZIP Code	County
		IN		

**VOTER'S CURRENT MAILING ADDRESS (If different from residence address)**

Street Address	City / Town	State	ZIP Code	County
		IN		

By filing this affidavit, I am requesting that my registration be updated to my new name or the residence address where I now reside as indicated above (If I changed residence to another precinct in the same county) as soon as the update is permitted. If I have changed residence from one county to another county in Indiana, I request that my registration in the county where I formerly resided be cancelled under IC 3-7-43-4. I understand that making a false statement on this affidavit is punishable under the penalties of perjury.

NOTE: This must be subscribed and sworn to before a person authorized to administer oaths within Indiana, such as a notary public, judge, clerk of the circuit court, member of a board of voter registration, precinct election officer, or absentee voter board member.

Signature of Voter (or initials of poll clerks witnessing oral affirmation if Box 2, 3, 4 or 5 applies)	Printed Name
---	--------------

Subscribed and sworn to before me, this \_\_\_\_\_ day of \_\_\_\_\_, 20\_\_\_\_.

My commission expires (mm/dd/yyyy): \_\_\_\_\_ County of Residence: \_\_\_\_\_ (Not required if absentee board member or precinct election officer)

Signature of Person Administering Oath	Printed Name	Title
--	--------------	-------



# Certificates of Error.

## C O F E

### ERROR BY COUNTY

If the voter's name is not on the  
Poll Pad (IPad).

Call the County Election Board.

219-755-3795

VOTER'S POLL LIST:

**2024 PRIMARY  
ELECTION**

Lake County Precinct

Certificate of Error or  
Provisional Ballot

Name of Voter    Signature of Voter    Address of Voter    DOB    Voter ID number    Voter ID number Type    Information



**DO NOT SIGN ON THIS PAGE!!! CALL  
OUR OFFICE FIRST 219-755-3795**



**EMERGENCY BALLOTS ARE ONLY USED FOR COMPLETE AND TOTAL MACHINE FAILURE, NOT BECAUSE OF LONG LINES.**

**CALL OFFICE FOR AUTHORIZATION TO USE EMERGENCY BALLOTS,  
AUTHORIZATION NUMBER MUST BE WRITTEN ON ENVELOPE #8.**

# CLOSING THE POLLS



# POLL CLOSING REMINDERS

**REMEMBER, ANY VOTER IN LINE AT 6:00 P.M. SHALL BE ALLOWED TO VOTE.**

**ONCE EVERYONE HAS VOTED AND LEFT THE POLLS**

**Follow the checklist in the Election Day Handbook.**

## **IMPORTANT REMINDERS:**

**Machines must be tallied**

**No precincts can tally machines until all voters have left the building. Be sure to tally each machine separately, using a new red tally card for each machine.**

**All machines must be taken apart and put back in their cases.**

**All ADA signs and equipment are to be placed by the machine. DO NOT BRING ADA OR MACHINES TO THE DROP OFF SITES UNLESS SPECIFICALLY INSTRUCTED**

**Polling places must be returned to their original setup.**

**The Inspector must return all election supplies to the drop off sites with Judge of the opposite party.**

# YOU WILL NEED A SEPARATE RED TALLY CARD AND ENVELOPE FOR EVERY VOTING MACHINE YOU HAVE IN YOUR PRECINCT



LABELED WITH INDIVIDUAL  
MACHINE NUMBER

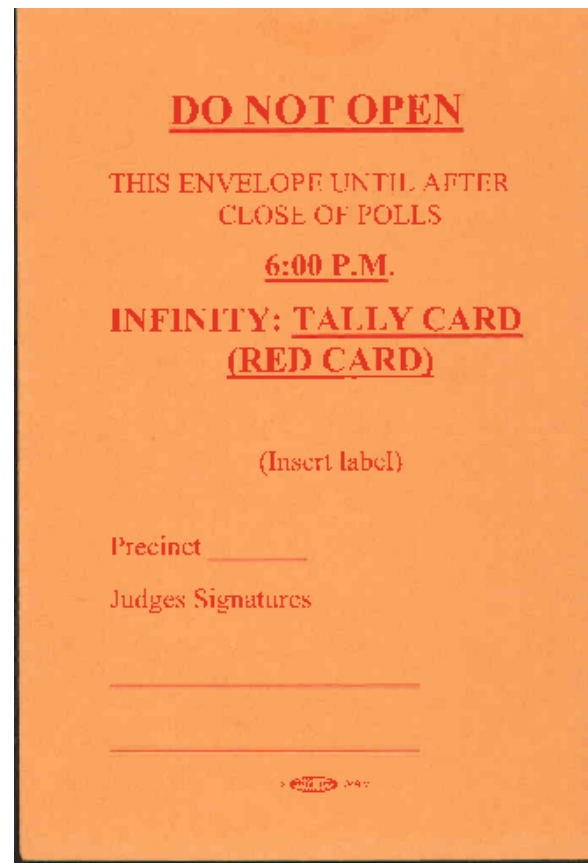

LABELED WITH ALL MACHINE NUMBERS  
FOR YOUR PRECINCT

# REMEMBER





# TALLY TAPES

PRINT 3 TALLY TAPES  
ONE TALLY TO RETURN WITH  
EQUIPMENT  
ONE TALLY FOR EACH PARTY  
**(DEMOCRAT AND REPUBLICAN)**

```
President of U.S. (1)
BARACK OBAMA (D) 0
MICH. MCCAIN (R) 0
BOB BAKER (L) 0
MR. LEVIN 0
Undervotes: 0 Contest Total: 0

Governor of Independent Govern (1)
JILL LOUIS THOMPSON (D) 0
MILO DANTFELS (R) 0
AMY CORNING (L) 0
WRITE-IN 0
Undervotes: 0 Contest Total: 0

Attorney General (1)
LINDA RENNE (D) 0
GREG BOBLEN (R) 0
WRITE-IN 0
Undervotes: 0 Contest Total: 0

Superintendent of Public In (1)
RICHARD E. WOOD (D) 0
Undervotes: 0 Contest Total: 0

Supreme Court Justice - Dickson (1)
YES 0
NO 0
Undervotes: 0 Contest Total: 0

IN Court of Appeals - Warden (1)
YES 0
NO 0
Undervotes: 0 Contest Total: 0

IN Tax Court Judge - Fisher (1)
YES 0
NO 0
Undervotes: 0 Contest Total: 0

Gender Exp. Assess (1)
YES 0
NO 0
Undervotes: 0 Contest Total: 0
```

PLEASE SIGN  
HERE

INSPECTOR AND BOTH  
JUDGES SIGN



# DROP OFF SITES

## Gov't Complex A-2<sup>nd</sup> Fl.,

Saint John – Hobart – Lake Station – Winfield – Tri-Creek  
Crown Point – Schererville – Merrillville – Cedar Lake  
Eagle Creek - West Creek

## Gary Airport-West Entrance (B Coleman Aviation)

Gary – East Chicago - Whiting

## Wicker Park (SOCIAL CENTER)

Hammond – Highland – Dyer – Munster-  
Griffith



# DROP OFF SITES

Inspectors please have these items ready for drop off:

1. Envelope #1 with Zero Proof tape, Start card, Vote cards & tally tapes inside. Also, insert Zip lock bag containing the Red Machine Tally cards only
2. POLL PAD AND JETPACK/CRADLEPOINT IN THEIR BOXES THE WAY YOU RECEIVED THEM
3. STATEMENT OF EXPENSE
4. Emergency Ballot Envelope #8 if used.
5. Red Provisional Bag



**FOR THE DROP OFF SITES, PLEASE HAVE THE FOLLOWING  
READY:**

STATION #1 - IPAD (POWER ON), CHARGER, AND RED TALLY CARDS  
(IN ZIPLOC BAG)

STATION #2 - HOT SPOT, WHITE ENVELOPE, AND BLACK BAG

STATION #3 - SIGN PAPERWORK - INSPECTOR/REPUBLICAN JUDGE  
(BRING A PEN)

STATION #4 - AUDITOR'S OFFICE/PAY CLAIMS/CERTIFICATION OF  
TRAINING



I do solemnly swear or affirm :

- (1) I will support the Constitution of the United States and the Constitution of the State of Indiana
- (2) I will faithfully and impartially discharge the duties of inspector, judge or poll clerk of this precinct under the law.
- (3) I will not knowingly permit any person to vote who is not qualified and will not knowingly refuse the vote of any qualified voter or cause any delay to any person offering to vote other than is necessary to procure satisfactory information of the qualification of that person as a voter.
- (4) I am now a bona fide resident of the county in which the precinct in which I am to act as a member of the election board is situated and, if required by law, am a qualified voter of that county.
- (5) I will not disclose or communicate to any person how any voter has voted at this election or how any ballot has been folded or marked.
- (6) I am able to read, write, and speak the English language.
- (7) I have no property bet or wagered on the result of this election.
- (8) I am not a candidate to be voted for at this election in this precinct, except as an unopposed candidate for a political party office.
- (9) If I am serving as an inspector, I am not the chairman or treasurer of the committee of a candidate whose name appears on the ballot.
- (10) I am not related to any person to be voted for at this election in this precinct as the spouse, parent, father-in-law, mother-in-law, child, son-in-law, daughter-in-law, grandparent, grandchild, brother, sister, brother-in-law, sister-in-law, uncle, aunt, nephew, or niece of that person, unless that person is an unopposed candidate.
- (11) I was trained as required by IC 3-6-6-40.



Thank you for serving as a Poll Worker





**WE CAN HELP!**

**LAKE COUNTY BOARD OF  
ELECTIONS AND REGISTRATION  
2293 N MAIN STREET  
CROWN POINT, IN 46307  
219-755-3795 & 219-755-3796**